

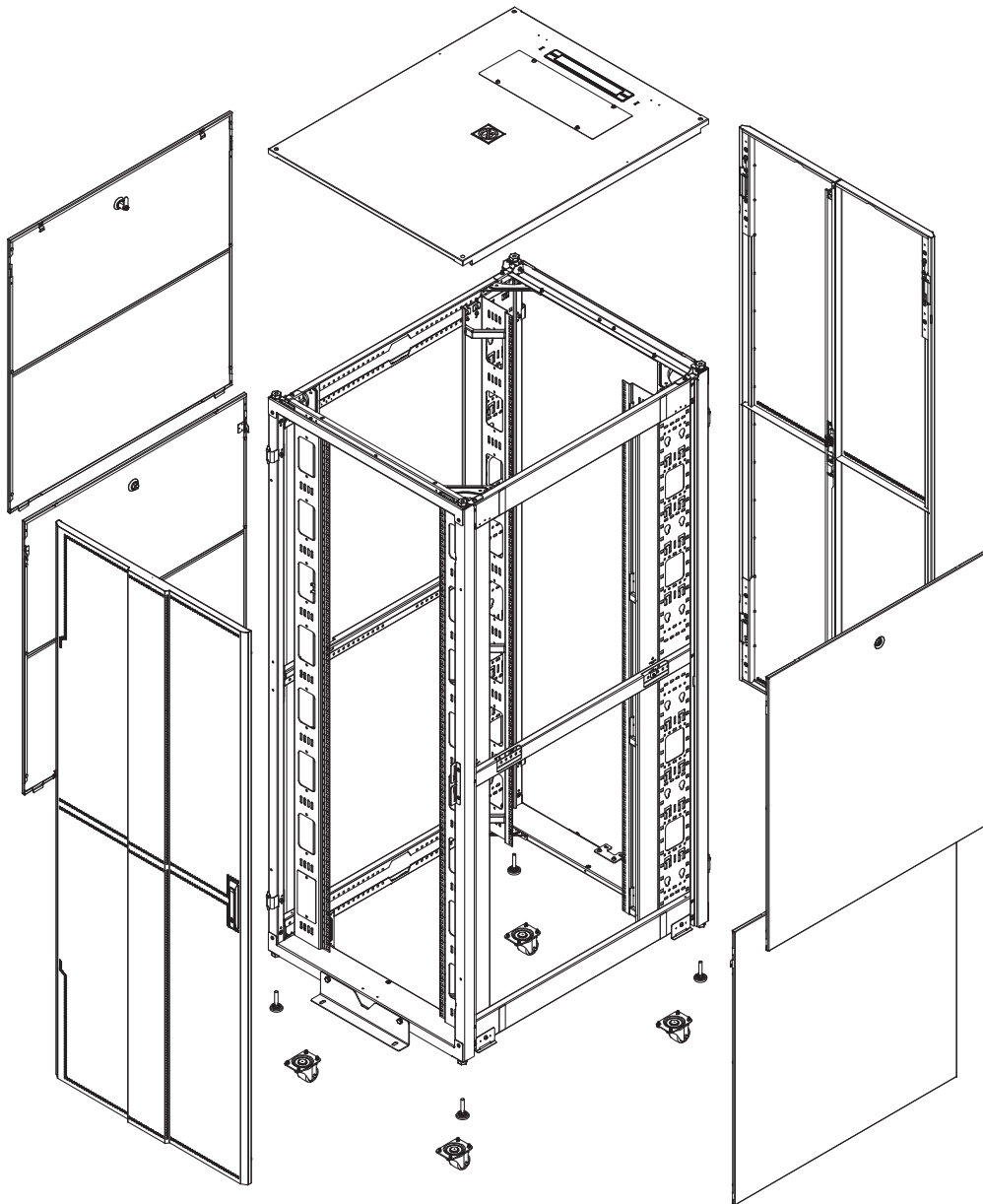

19" Standard Cabinet
Complies to EIA-310-E and IEC-60297-1,2

Assembly Guide

ARION SOLIS 800W Series



Contents

Arion Solis 800W Exploded View	1
Tool & Hardware	2
Frame Structure Assembly	3
Leveling Feet Assembly	10
Caster Assembly	10
Middle Side Brace Assembly	11
Top Panel Assembly	11
PMA Set Assembly	13
Side Panel Assembly	14
Single Door Assembly	15
Split Door Assembly	17
PDU Rail Assembly	18
Product Information	19



Arion Solis 800W Exploded View

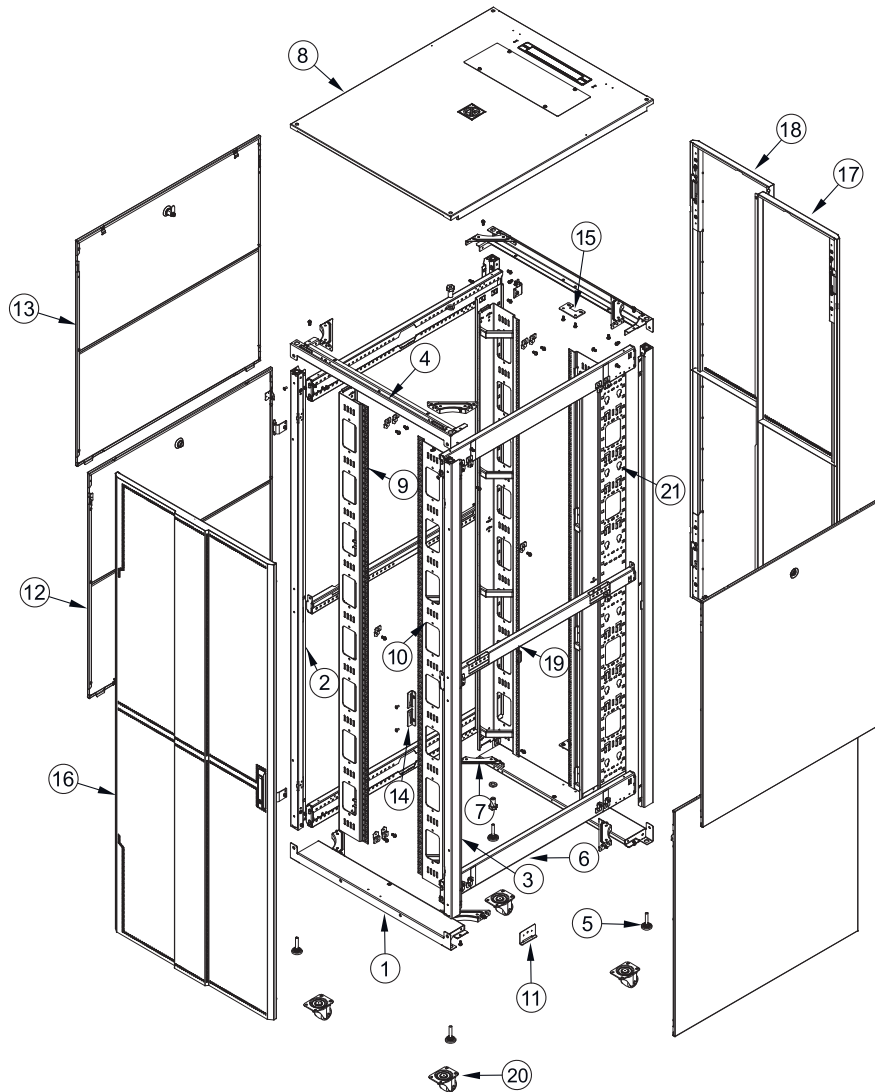

Arion Solis 800 series enclosure. Basic unit with select optional parts

Item	Drawing Title	QTY.
1	Frame Front/Rear (Bottom)	2
2	Vertical Post (LH)	2
3	Vertical Post (RH)	2
4	Frame Front/Rear (Top)	2
5	Leveling Feet M10x1.50x62	4
6	PMA Mounting Channel	4
7	Angle Stiffener	8
8	Top Panel Assy.	1
9	PMA Assy. (LH)	2
10	PMA Assy. (RH)	2

Item	Drawing Title	QTY.
11	Side Panel Support Brkt.	4
12	Side Panel Assy.(Bottom)	2
13	Side Panel Assy.(Top)	2
14	Door Latch Brkt. (0352-02)	1
15	Split Door Latch Brkt. (0352-01)	2
16	Single Door Perforate Assy.	1
17	Split Door Perforate Assy. (LH)	1
18	Split Door Perforate Assy. (RH)	1
19	Middle Side Brace	2
20	Caster 2 Inch (option)	4
21	PDU Rail Assy. 42U (option)	2



TOOLS AND HARDWARE

» Tools Recommended for Assembly

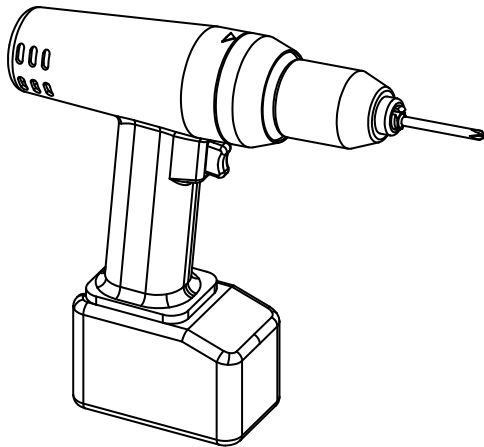

Wireless Screw Driver, Torx Head



Hexagon Socket No. 24

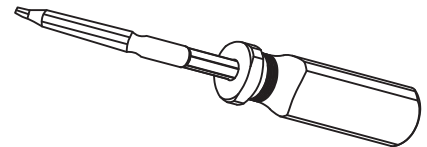

Screw Driver T30

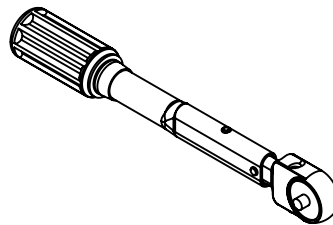

Torque Wrench

» Hardware Supplied

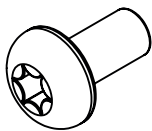

Screw Torx M6x12
102 pcs.

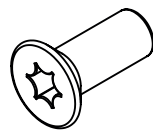

Screw Torx Taper M6 x 12
10 pcs.

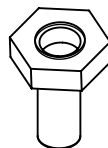

Nut Hex head M16
8 pcs.



Spring Washer M16
8 pcs.

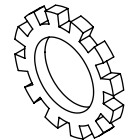

Tooth Washer M6
6 pcs.

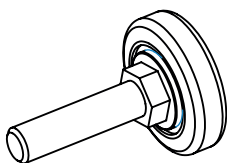

Levelling Feet M10
4 pcs.

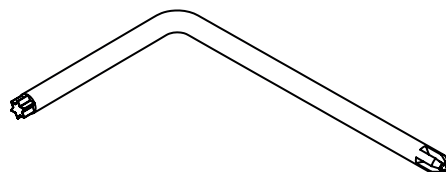

Philips/Torx T30 L-Wrench
1 pc.

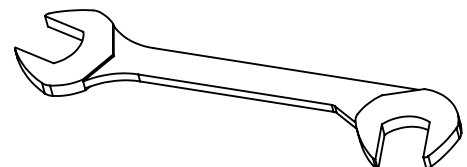

Open End Wrench NO.13/14
1 pc.



FRAME STRUCTURE ASSEMBLY

Exploded view of frame structure.

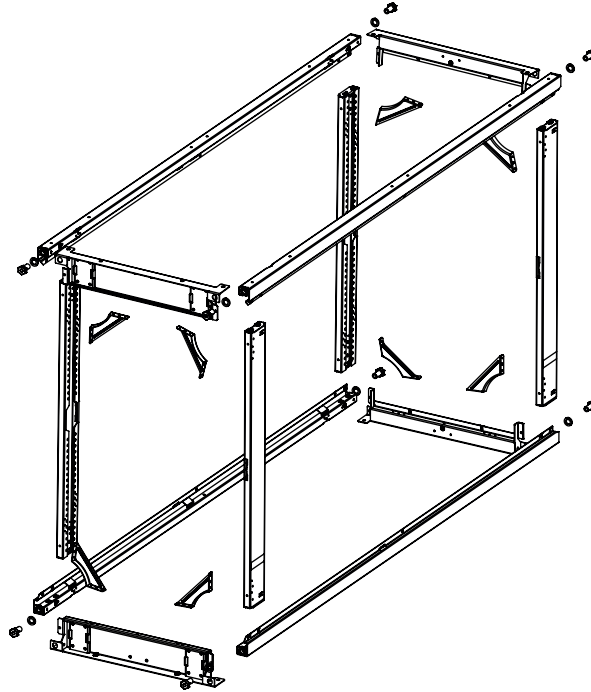

Step 1: Side Frame Assembly.

1.1) Insert two hooks of PMA mounting channel into cut out on vertical post then move it down.

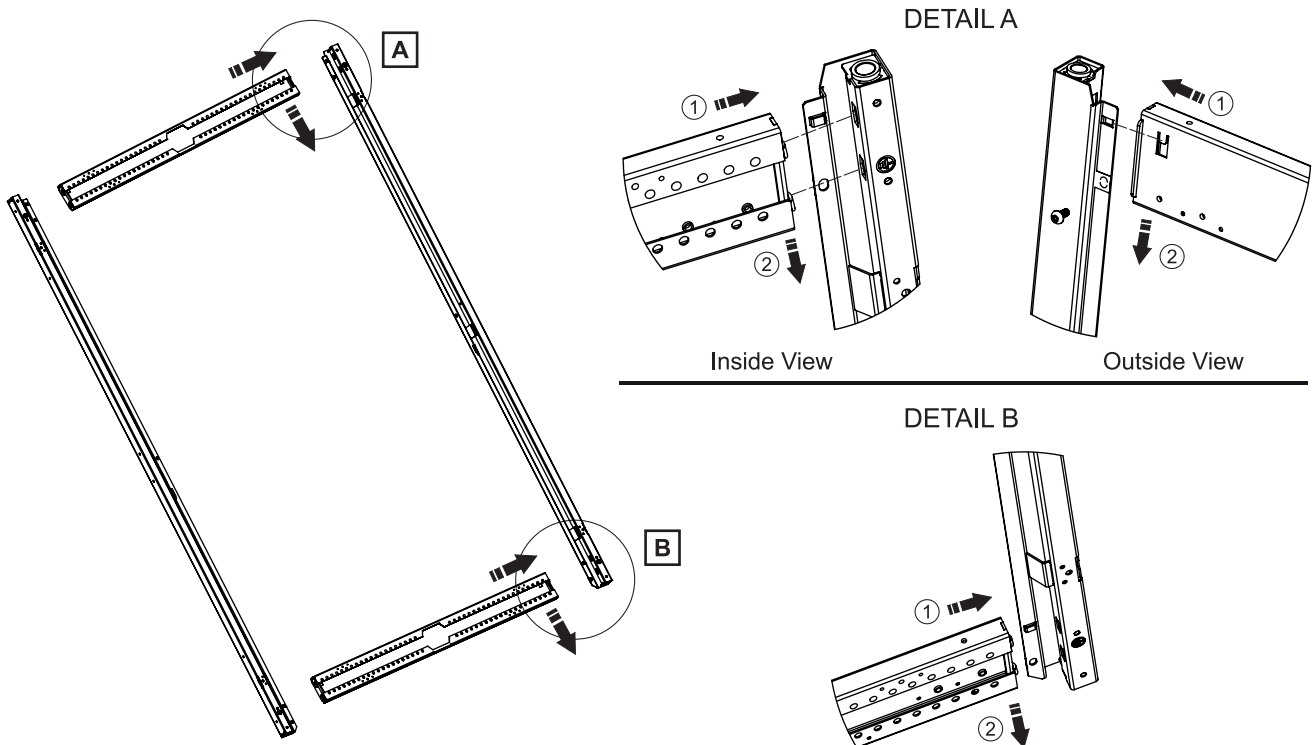

1.2) Fix screw M6x12 hand tight.

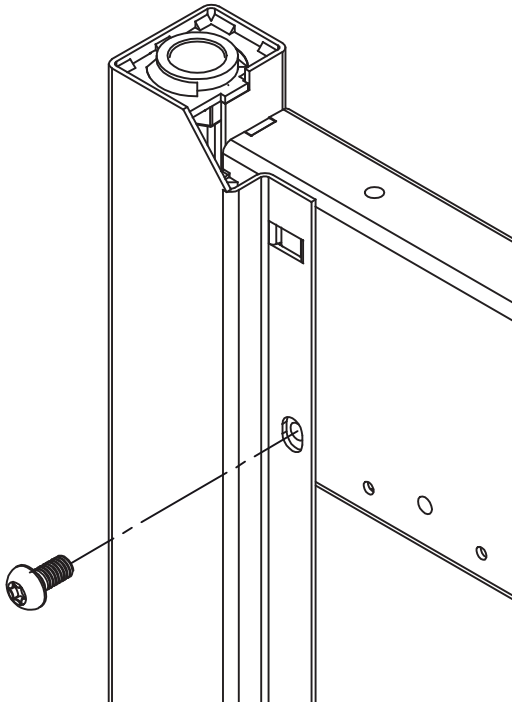

Hardware	Qty.
Screw torx M6 x 12	8

1.3) Repeat step 1.1-1.2 at the other three corners.

1.4) Repeat step 1.1-1.3 to assemble the other side frame.

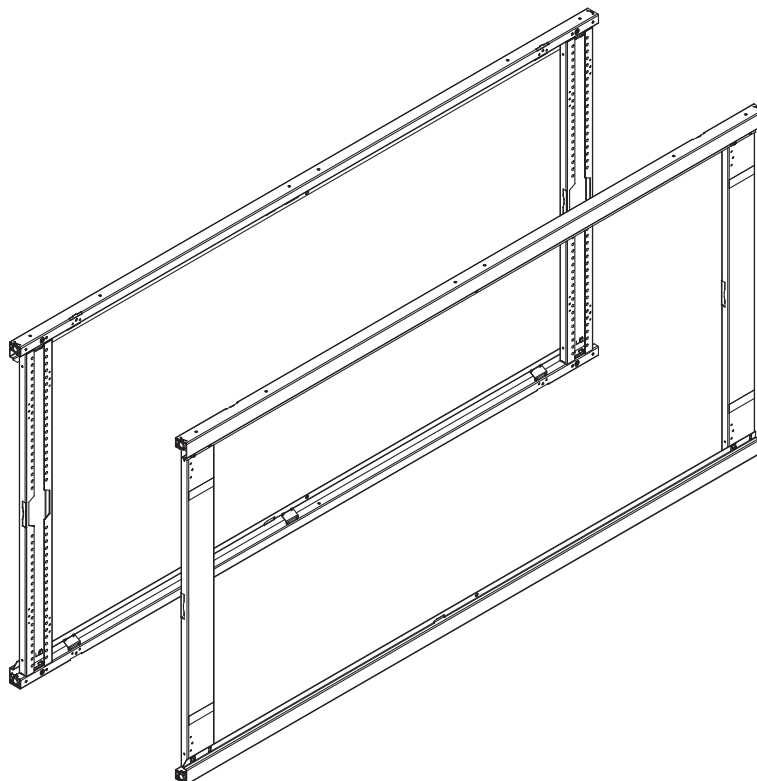

Step 2: Basic Frame Assembly. See detail C.

2.1) Install frame front/rear (top) to side frame assembly.

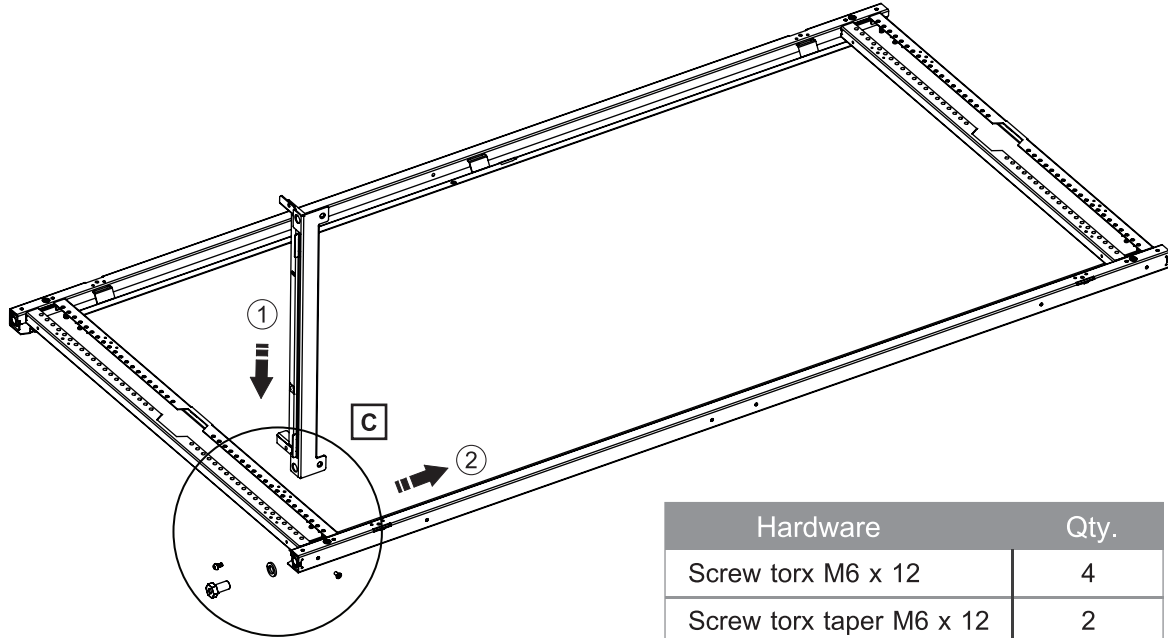

Hardware	Qty.
Screw torx M6 x 12	4
Screw torx taper M6 x 12	2
Nut Hex Head M16	2
Spring Washer M16	2

2.2) Fix frame front/rear (top) to side frame assembly by nut and spring washer M16 hand tight balloon number 1.

2.3) Fix screw torx M6 at balloon numbers 2 and 3 then screw torx taper M6 at balloon number 4, both of them hand tight.

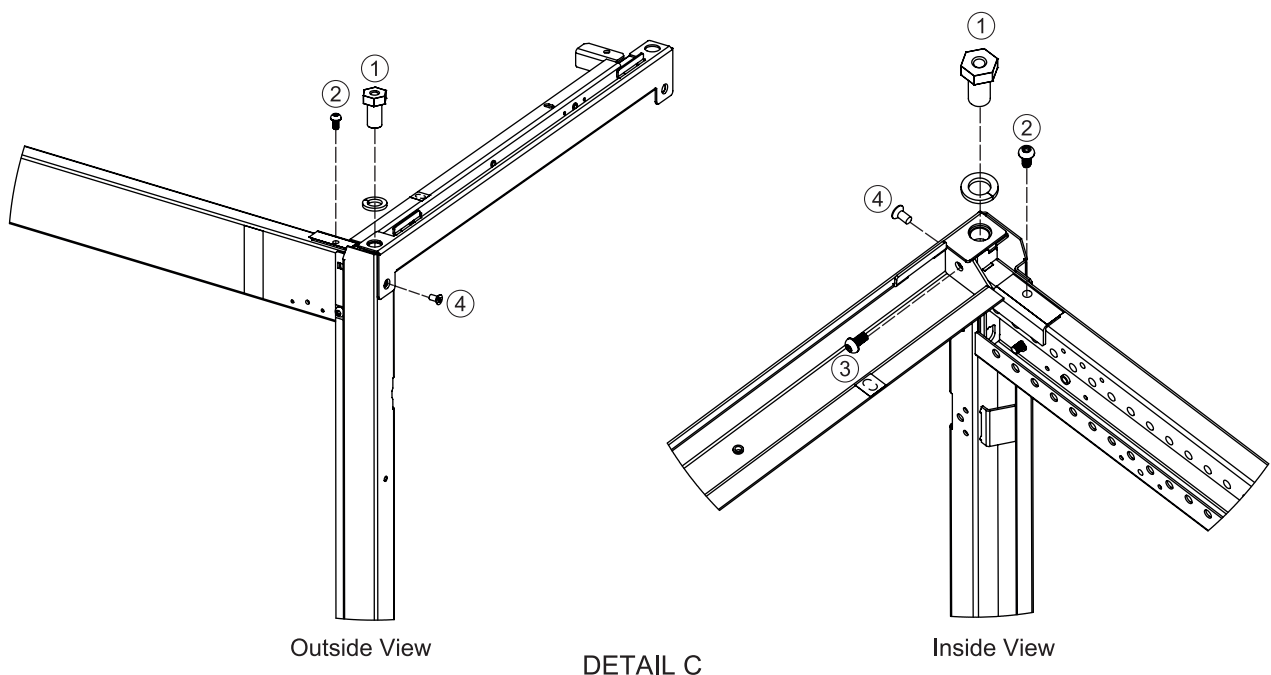

2.4) Install frame front/rear (bottom) with side frame. See detail D.

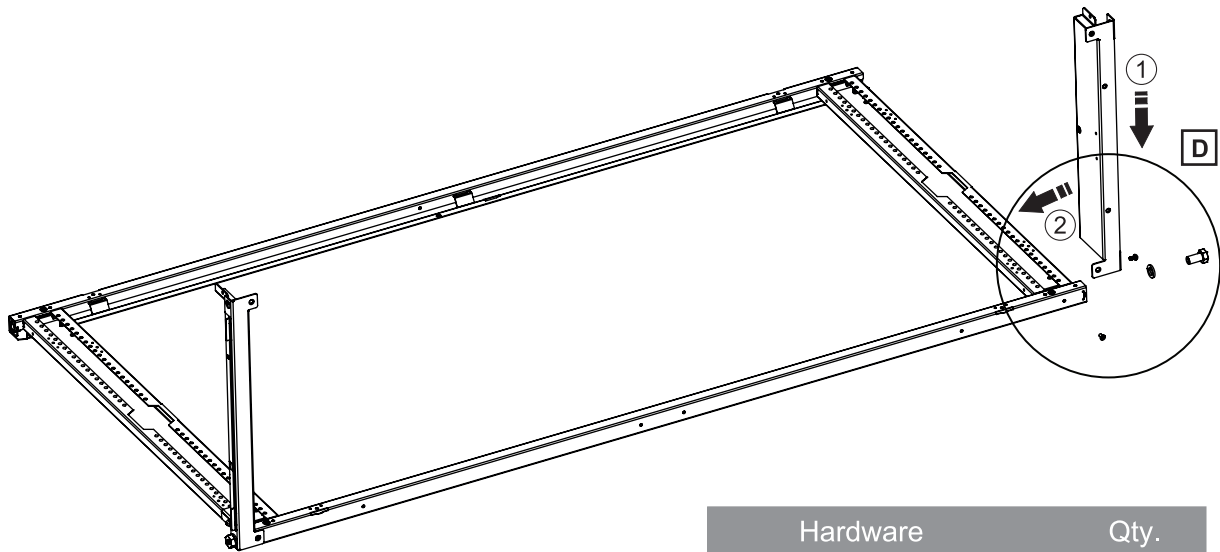

Hardware	Qty.
Screw torx M6 x 12	4
Screw torx taper M6 x 12	2
Nut Hex Head M16	2
Spring Washer M16	2

2.5) Fix frame front/rear (bottom) to side frame assembly by nut and spring washer M16 hand tight balloon number 1.

2.6) Fix screw torx M6 at balloon numbers 2 and 3 then screw torx taper M6 at balloon number 4, hand tight.

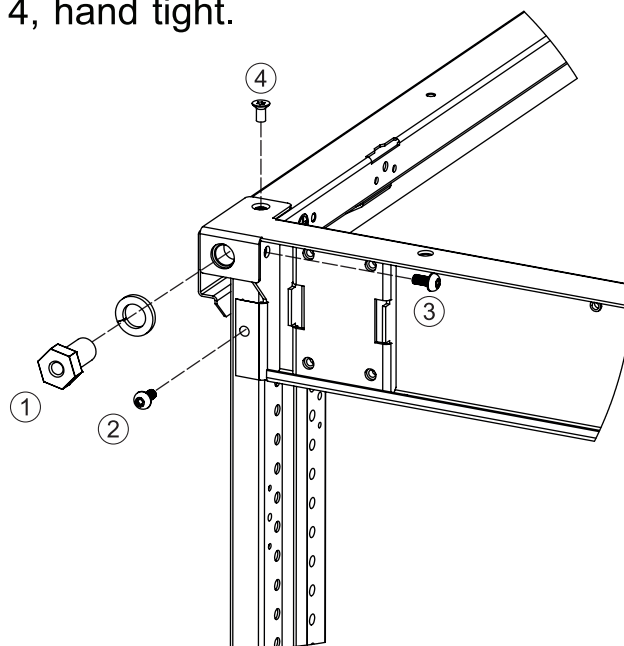

DETAIL D



2.7) Repeat step 2.1-2.6 on the other end of side frame. The complete assembly is shown below.

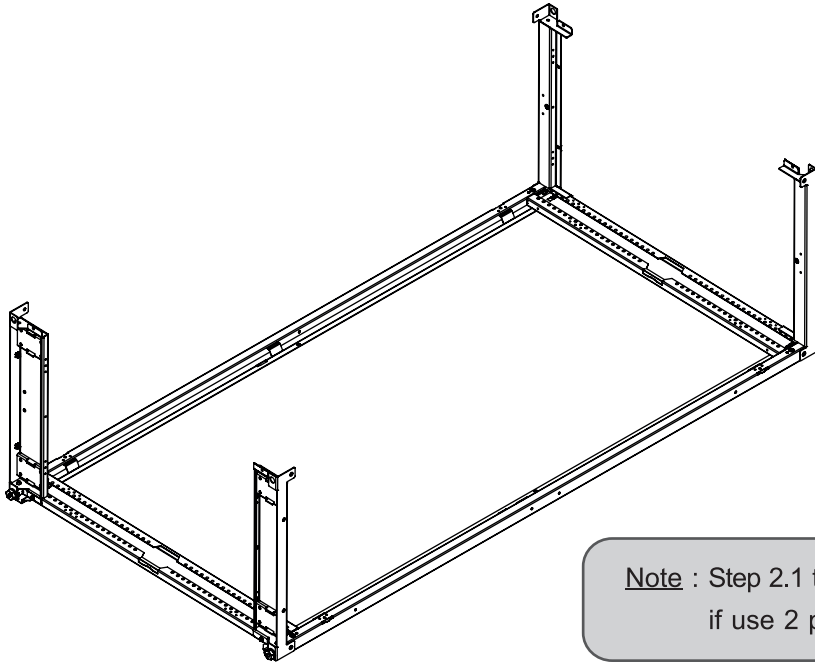

Note : Step 2.1 to 2.7 can be done at the same time, if use 2 people to assemble.

2.8) Install angle stiffener at 4 corners of frame structure hand tight with screw torx M6 2 pieces at each position. Flat surface of angle stiffener faces into the cabinet. See detail F.

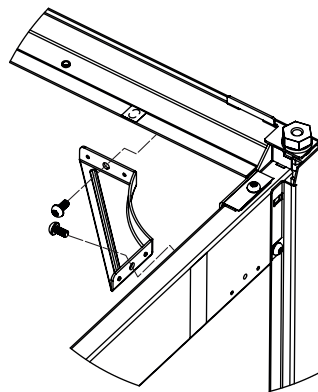
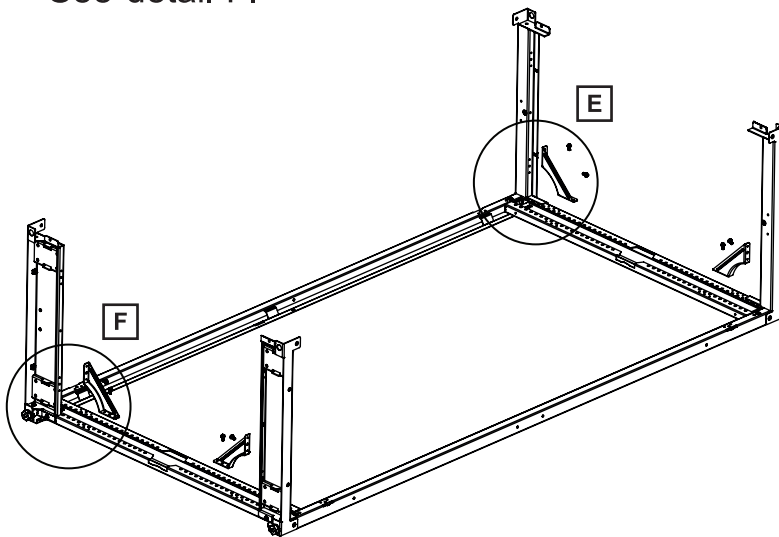

DETAIL E

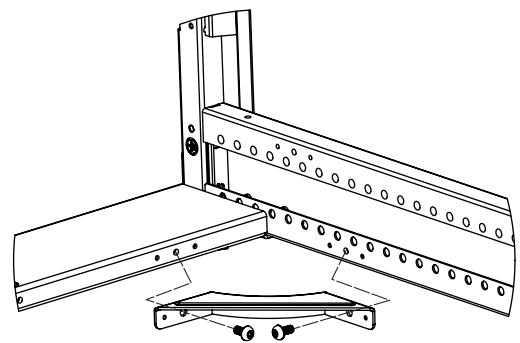

DETAIL F

Hardware	Qty.
Screw torx M6 x 12	8



2.9) Repeat step 2.1-2.7 to install the other side frame to this frame structure.

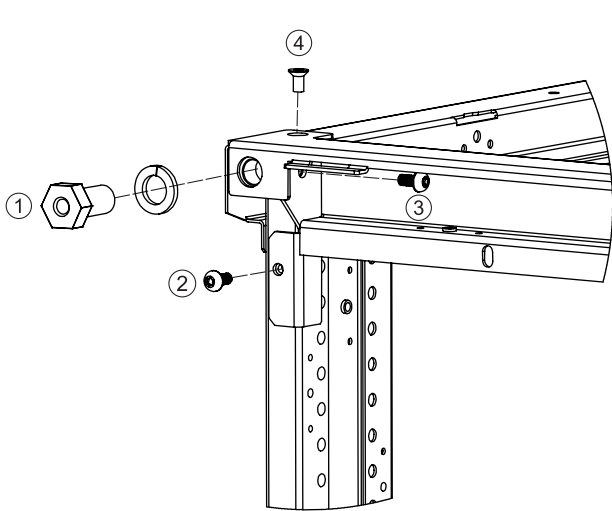
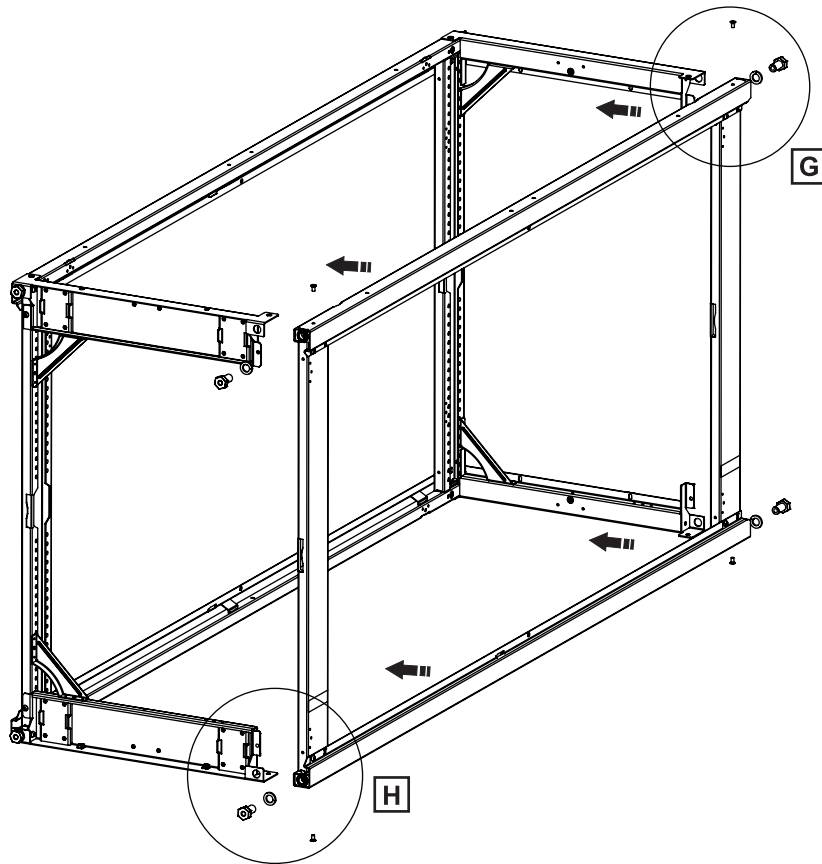

DETAIL G

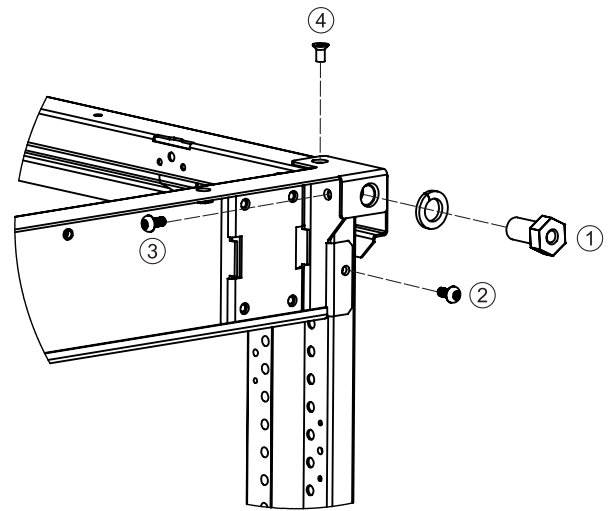

DETAIL H

Hardware	Qty.
Screw torx M6 x 12	8
Screw torx taper M6 x 12	4
Nut Hex Head M16	4
Spring Washer M16	4



2.10) Repeat step 2.8 to install the other 4 pieces of angle stiffener to the 4 corners of frame structure. Flat surface of angle stiffener faces into the cabinet. See detail J.

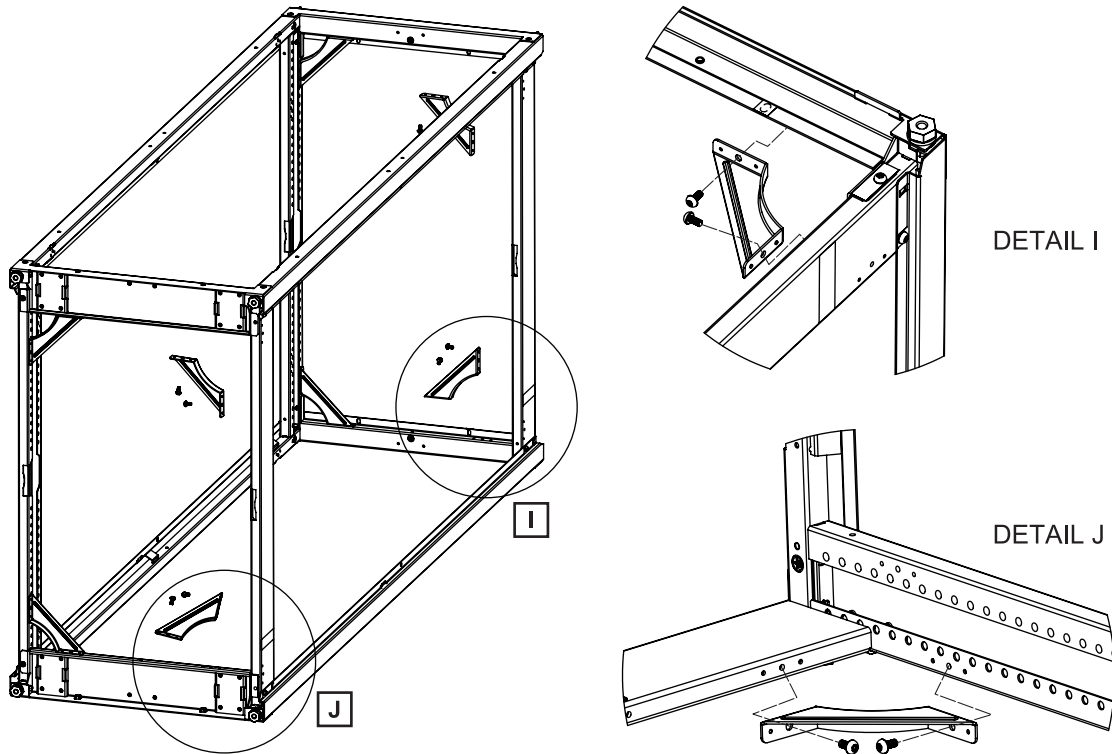

Hardware	Qty.
Screw torx M6 x 12	8

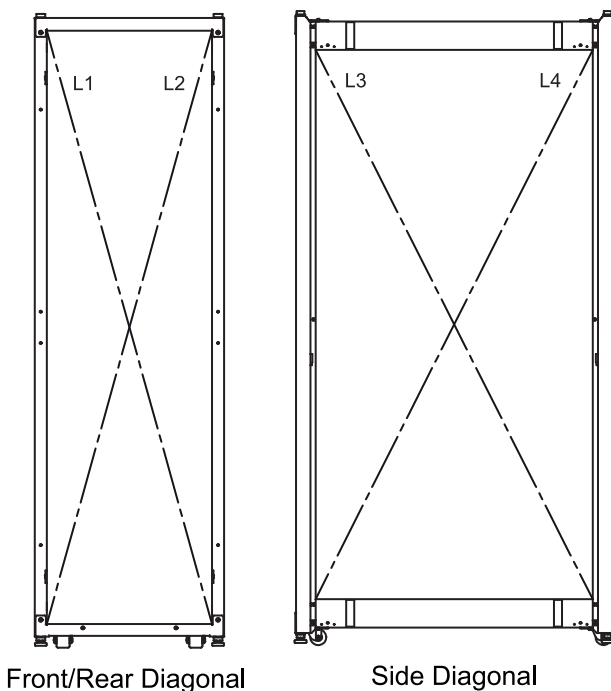

Using the torque setting below:
 55 ft.lbs for nut M16
 75-80 in.lbs for screw torx
 and screw torx taper M6X12

Note : - Before tightening should check diagonal of front and side, dimension between L1 = L2 and L3 = L4
 - Top frame and bottom frame are different, pls check before install.
 - If top frame and bottom are different (tolerance +/-2 mm), pls check and readjust before continuing.



Leveling Feet Assembly

Step 3: Install 4 leveling feet to bottom frame into nut M16.

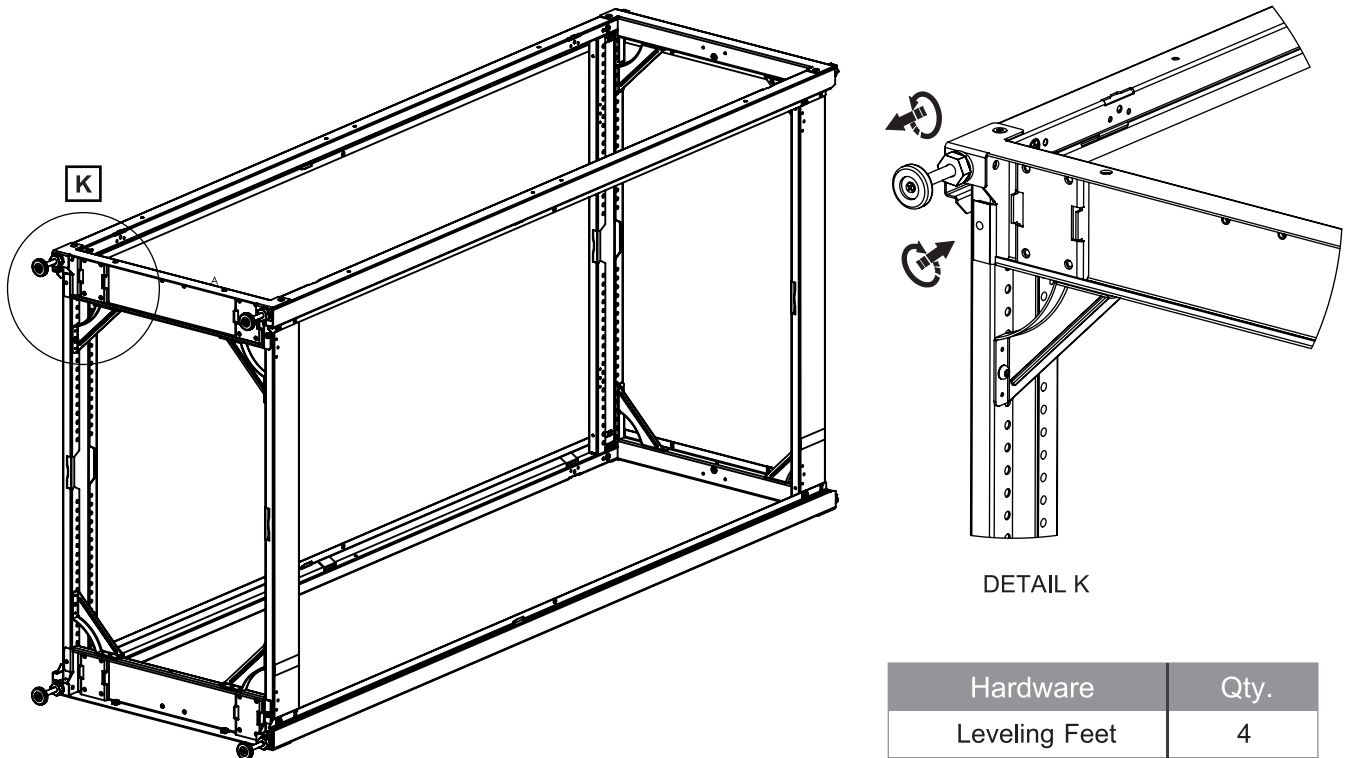

Caster Assembly

Optional Part: Install caster plate to bottom frame front/rear (bottom) by screw torx M6 and tighten.

Hardware	Qty.
Caster 2.0"	4
Screw Torx M6	16

Set Torque 75-80 in.lbs

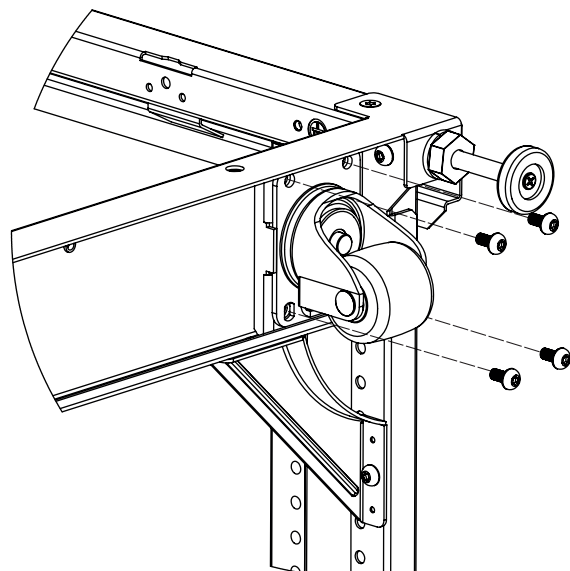

Middle Side Brace Assembly

Step 4:

- 4.1) Put middle side brace inside frame at middle position of vertical post.
- 4.2) Push middle side brace until it attaches to the vertical post. See detail U.
- 4.3) Push down until the middle side brace contacts the stopper. Check alignment between screw hole and tapped hole on the frame, then fix a M6 torx screw at 75 - 80 in.lbs torque.

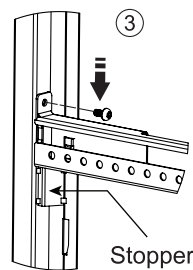
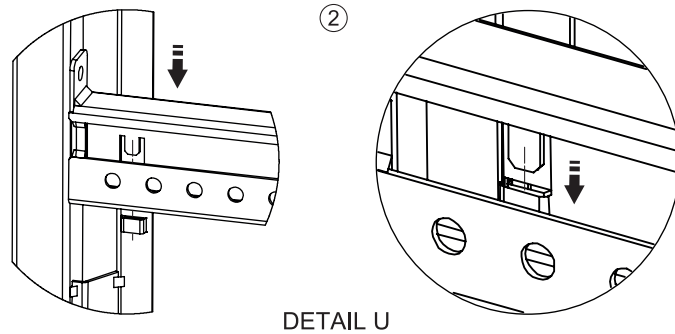
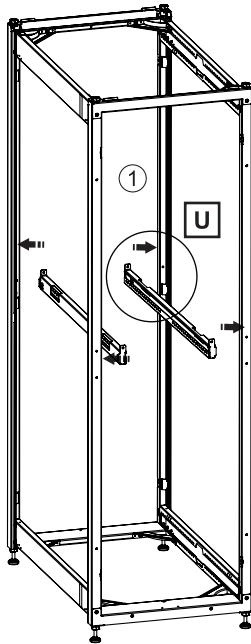

Hardware	Qty.
Screw torx M6 x 12	4

Set Torque 75-80 in.lbs

Top Panel Assembly

Step 5:

- 5.1) Put the top panel on the top surface of basic frame structure, leaving about 10 mm. protruding over the front side.
- 5.2) Raise back side of top panel (cut out side) 15 mm.
- 5.3) Move top panel backward until it stops.
- 5.4) Lower the top panel until it touches the frame.

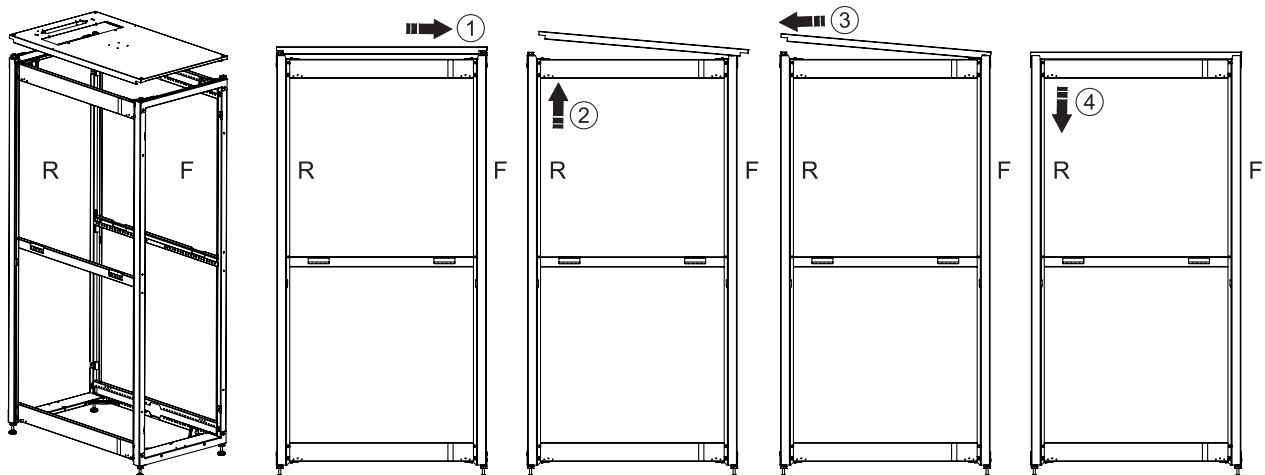

5.5) Fix top panel to back top frame with screw torx M6, see detail L.

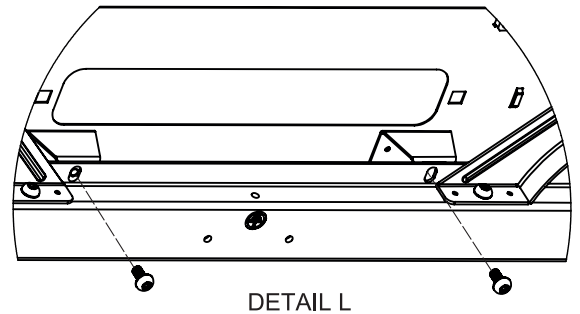
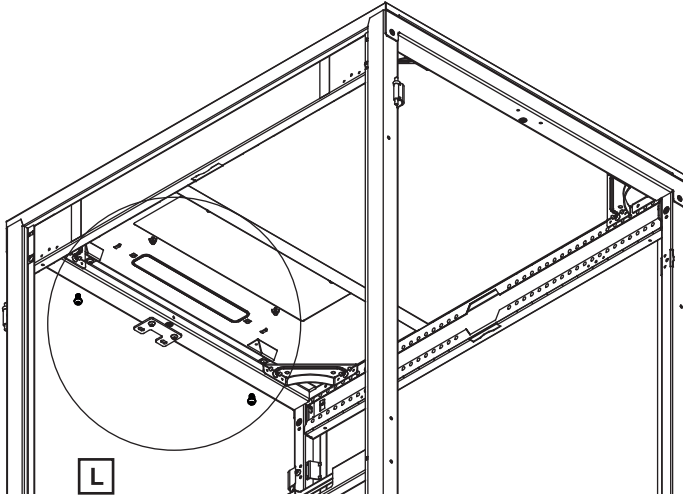

Hardware	Qty.
Screw torx M6 x 12	2

Set Torque 75-80 in.lbs

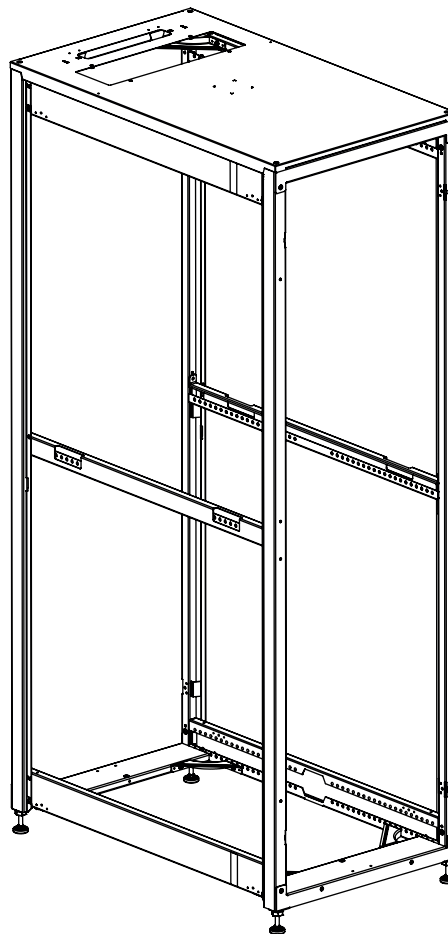

Note : After installing top panel, the cut out side of Top panel is the back side.



PMA SET ASSEMBLY

Step 6:

- 6.1) Put PMA at the center of PMA mounting channel.
- 6.2) Slide PMA to desired position then adjust mounting hole on PMA to fit with hole on PMA mounting channel.

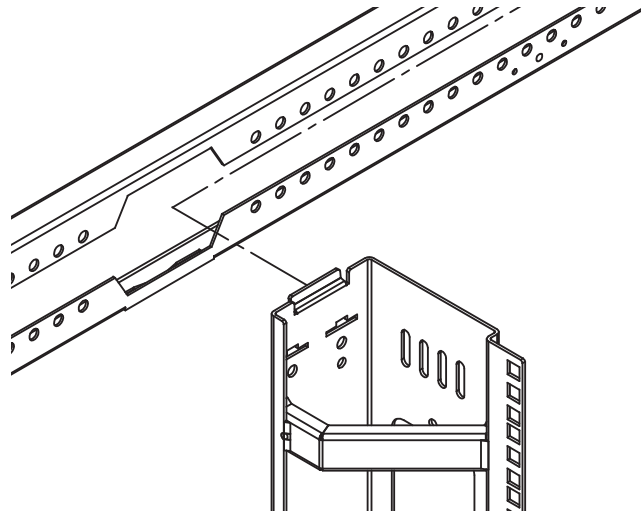

Note : Remember to leave enough space if you intend to install other accessories such as PDU rail.

- 6.3) At upper and middle side of PMA insert PMA fixing bracket through the cut out then push the bracket up until it completely touches the PMA.
- 6.4) Fix PMA to PMA mounting channel with screw torx M6x12 hand tight.
- 6.5) At lower side of PMA insert PMA fixing bracket through the cut out then push the bracket down until it completely touches with PMA.

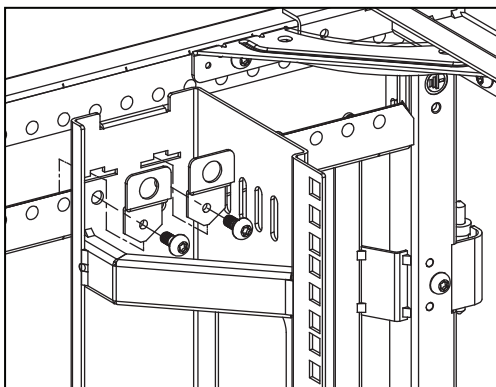

Upper Side

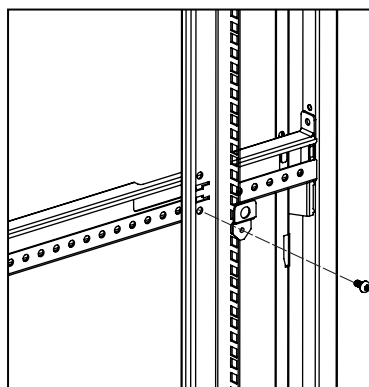

Middle Side

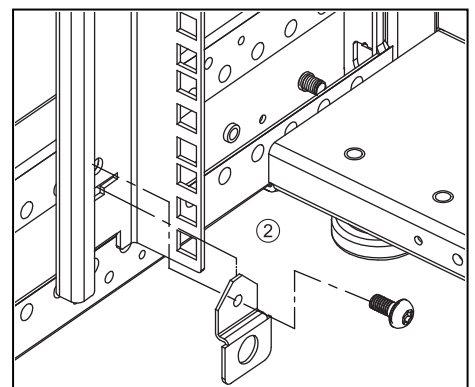

Lower Side

Hardware	Qty.
Screw torx M6 x 12	20

Set Torque 75-80 in.lbs



SIDE PANEL ASSEMBLY

Step 7:

7.1) Install side panel support bracket 4 pieces to bottom frame and fix screw torx M6 x12 at torque 75–80 in.lbs.

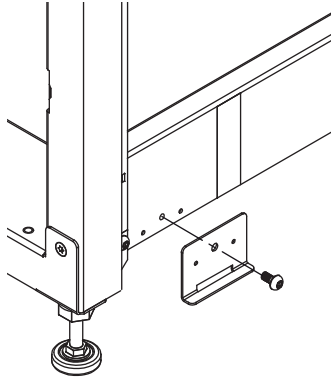

Hardware	Qty.
Screw torx M6 x 12	4

Set Torque 75-80 in.lbs

7.2) Lift up bottom side panel then insert 2 hooks at bottom of side panel into rectangular cut out on side panel support bracket. Lower side panel and push it forward.

7.3) Lift side panel up again slowly until upper hook on side panel engages cut out latch on vertical post then lower side panel down.

7.4) Put top side panel on bottom side panel by keeping hooks inside.

7.5) Push side panel forward until it stops. Turn the key to lock.

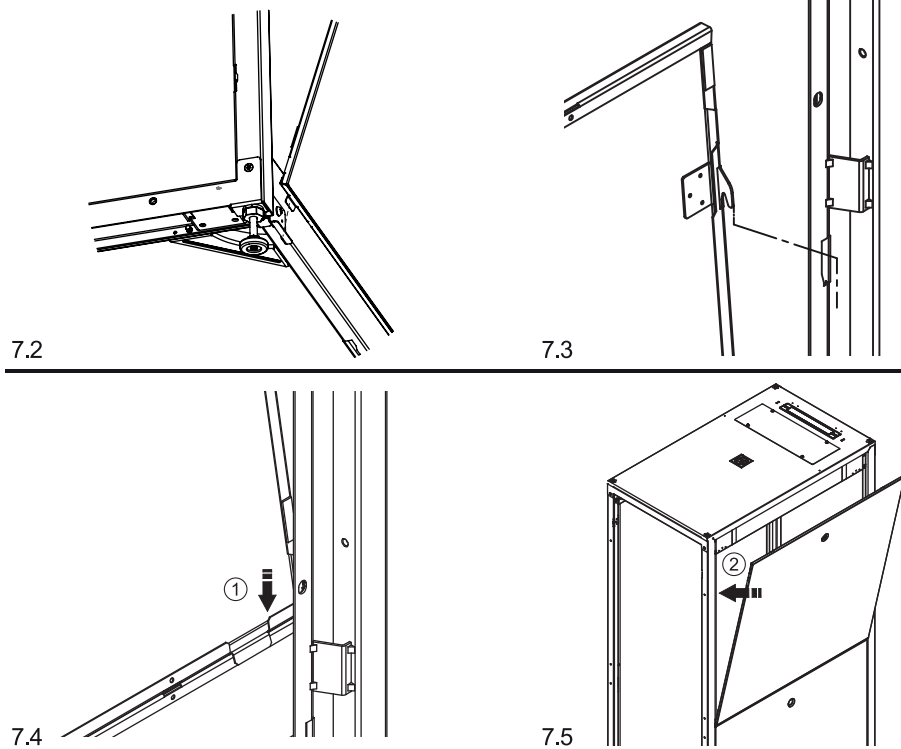

Note : This step hides middle side brace parts to display clear view of side panel installation.



Side panels installed

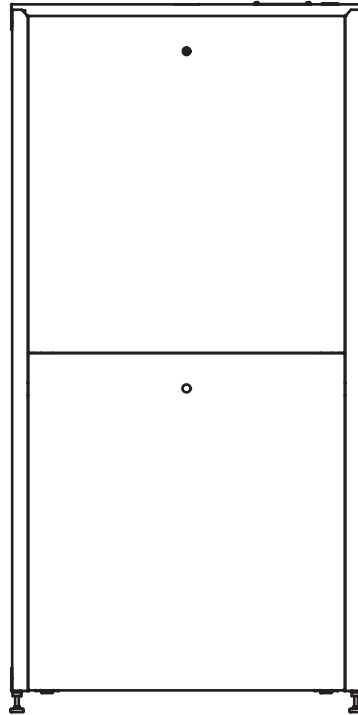

SINGLE DOOR ASSEMBLY

Step 8:

8.1) Install door hinge 2 pieces. See detail O1. And door latch bracket to vertical post. See detail O2.

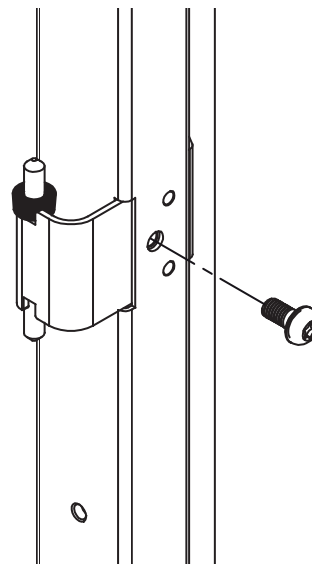
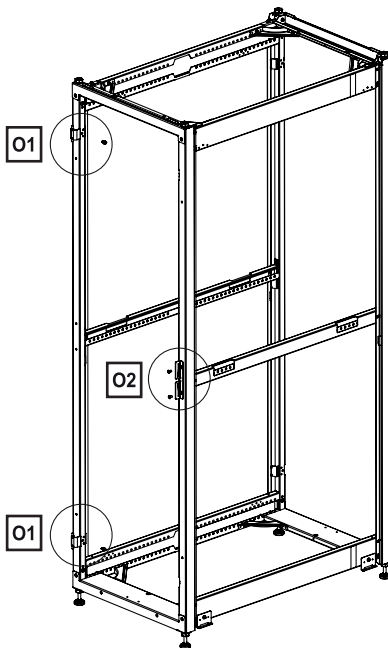

DETAIL O1

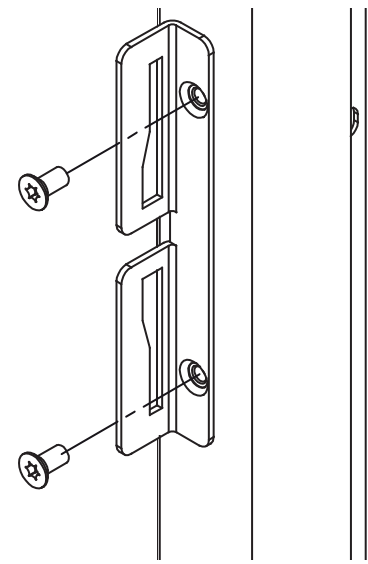

DETAIL O2

Note : These assembly steps put single piece door in front and split door in rear of cabinet. Doors can be installed per user requirements.



8.2) Put door onto door hinges . See detail O3. Attach ground wire after door is installed.
See detail O4.

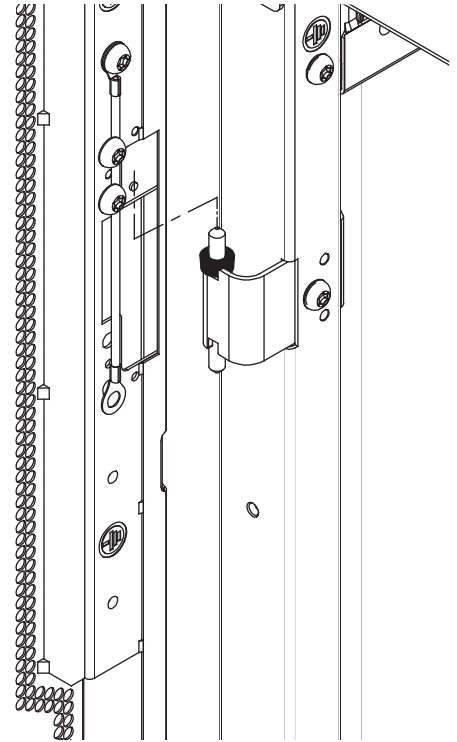
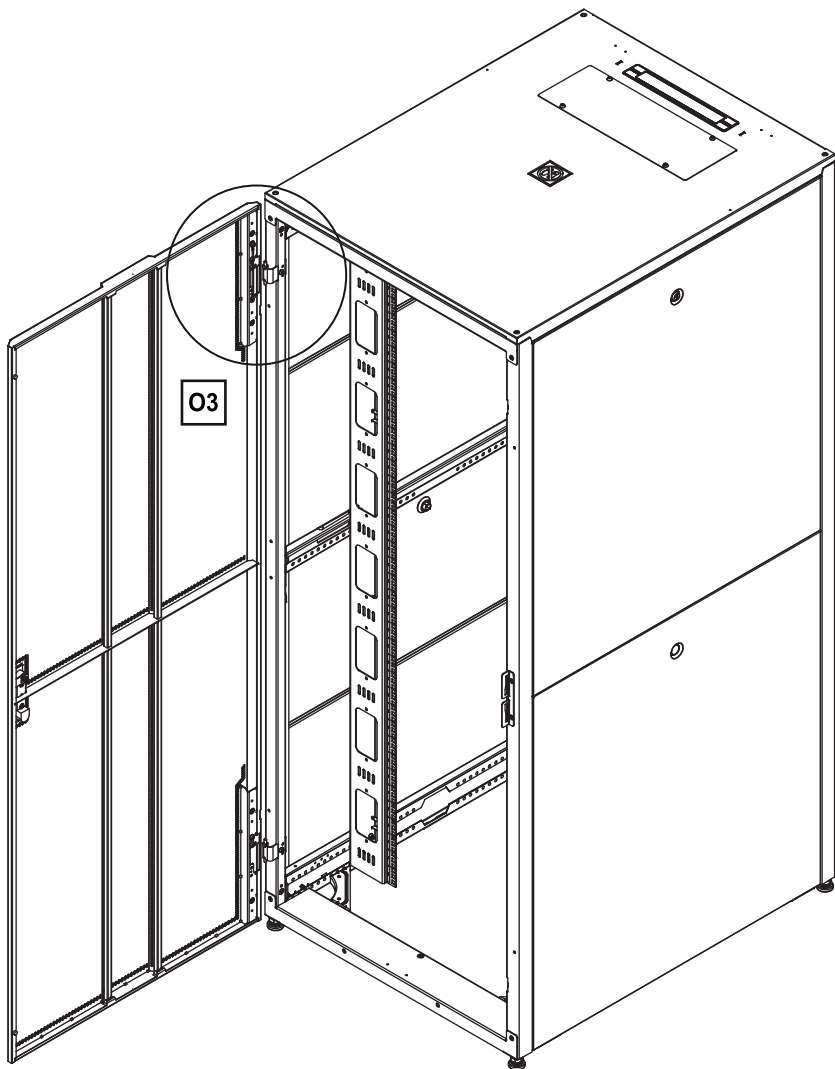

DETAIL O3

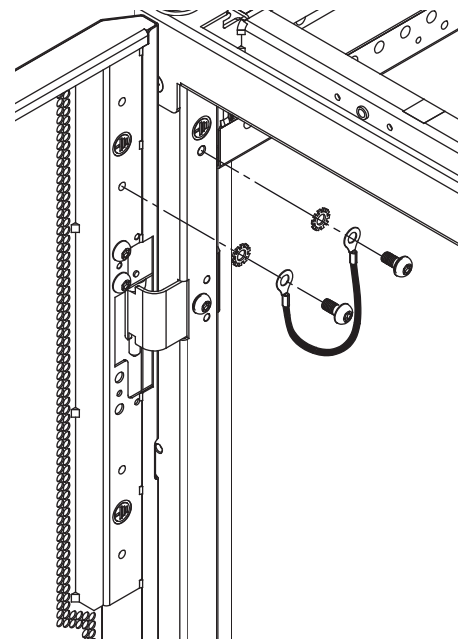

DETAIL O4

Hardware	Qty.
Screw torx M6 x 12	4
Screw torx taper M6 x 12	2
Tooth washer M6	2

Set Torque 75-80 in.lbs



SPLIT DOOR ASSEMBLY

Step 9:

9.1) Install door hinge 4 pieces to vertical post and split door latch 2 pieces to frame top and bottom. See detail P1, P2.

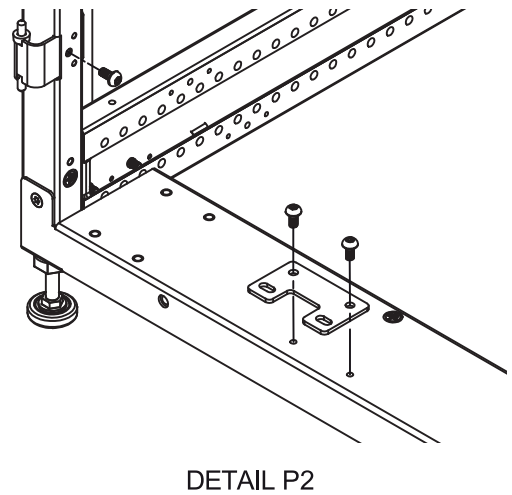
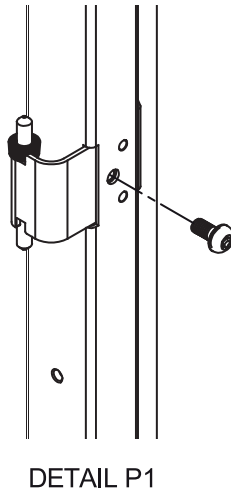
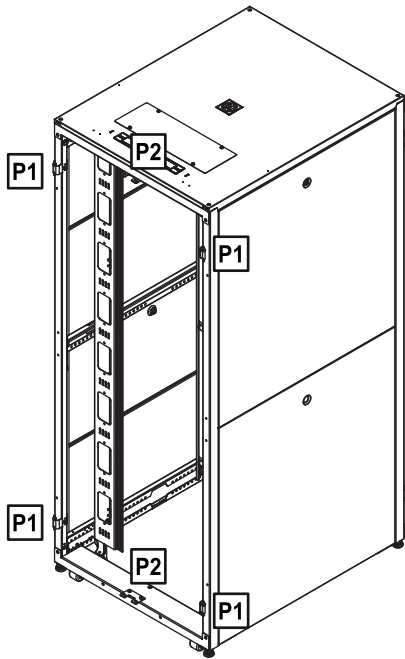

8.2) Insert hinge bushings on the four door hinges. Put split door onto door hinges. See detail P3. Attach ground wire after door is installed. See detail P4.

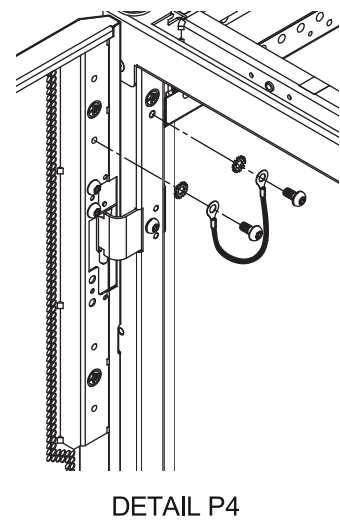
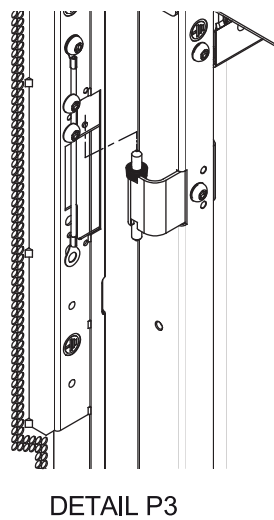
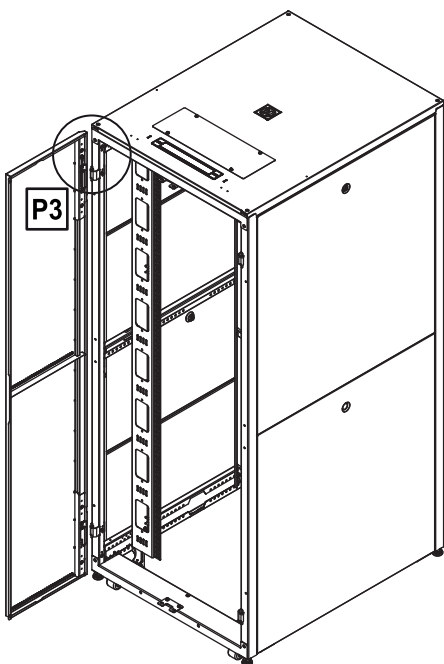

Hardware	Qty.
Screw Torx M6 x 12	12
Tooth washer M6	4

Set Torque 75-80 in.lbs



PDU RAIL ASSEMBLY

Option Part:

1. Install PDU rail to the PMA mounting channel. Most users put at the rear of cabinet. See detail T1.

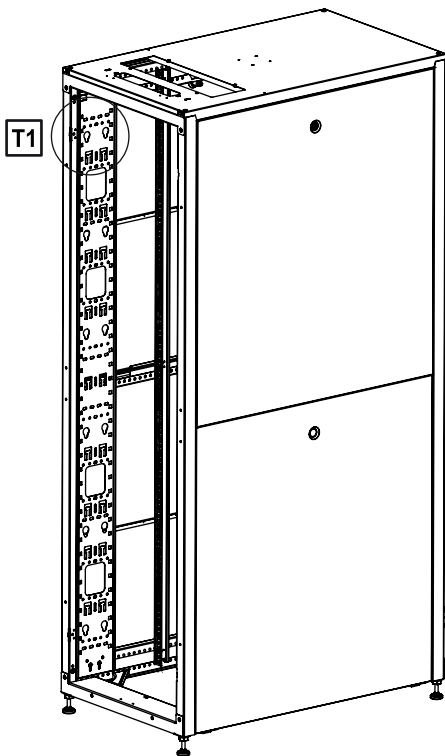

Upper Side

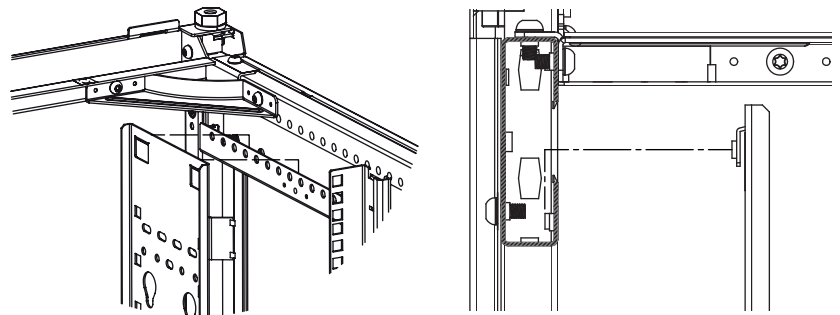

DETAIL T1

Hardware	Qty.
Screw Torx taper M6 x 12	8

2. Slide the 2 screws at the bottom up until the hooks on rear side of PDU rail engage with holes of PMA mounting channel, then turn screw driver to lock and set torque at 75 – 80 in.lbs. See step 1, 2 detail T2.

Lower Side

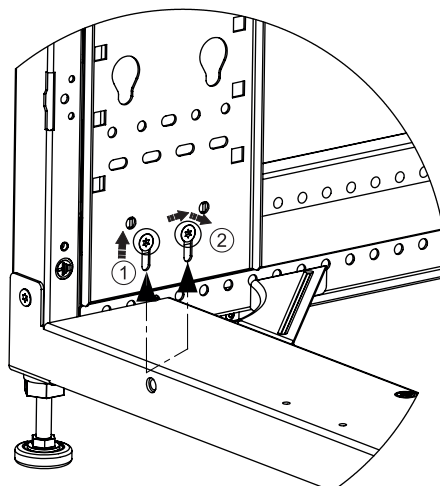

DETAIL T2



Overall Dimension of Assembled Arion Solis (standard top version shown)

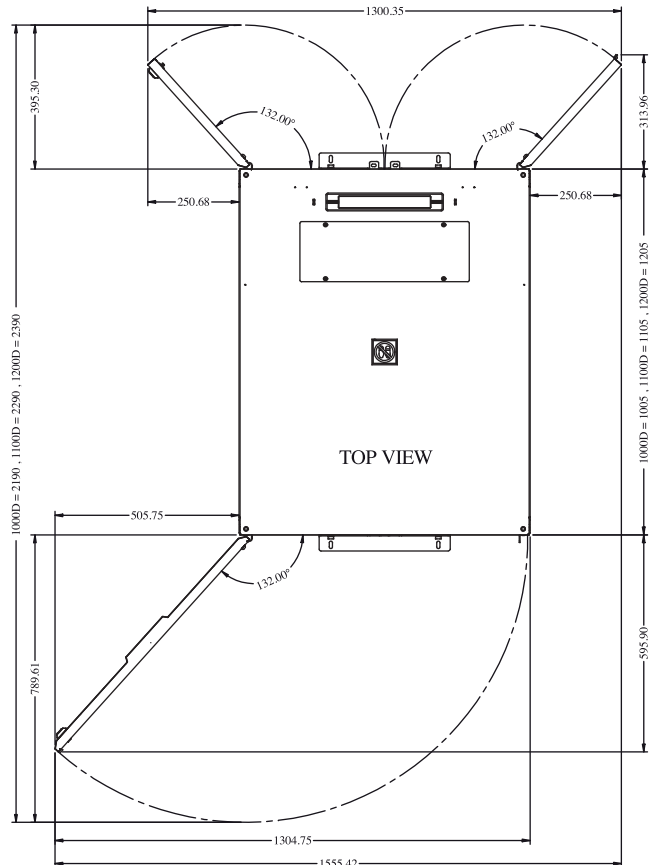
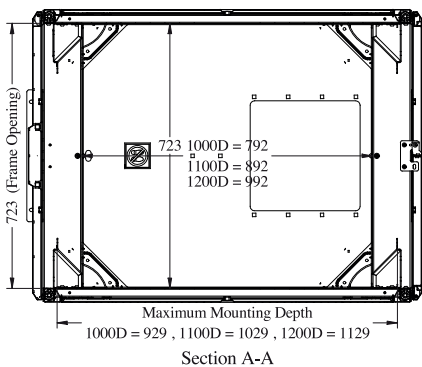
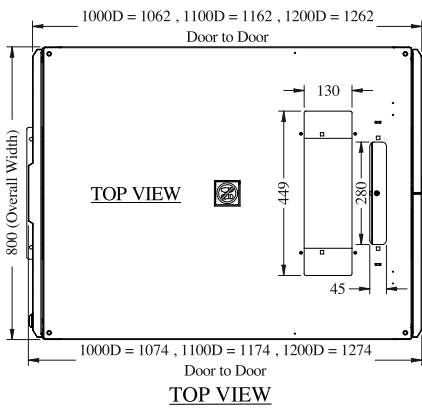
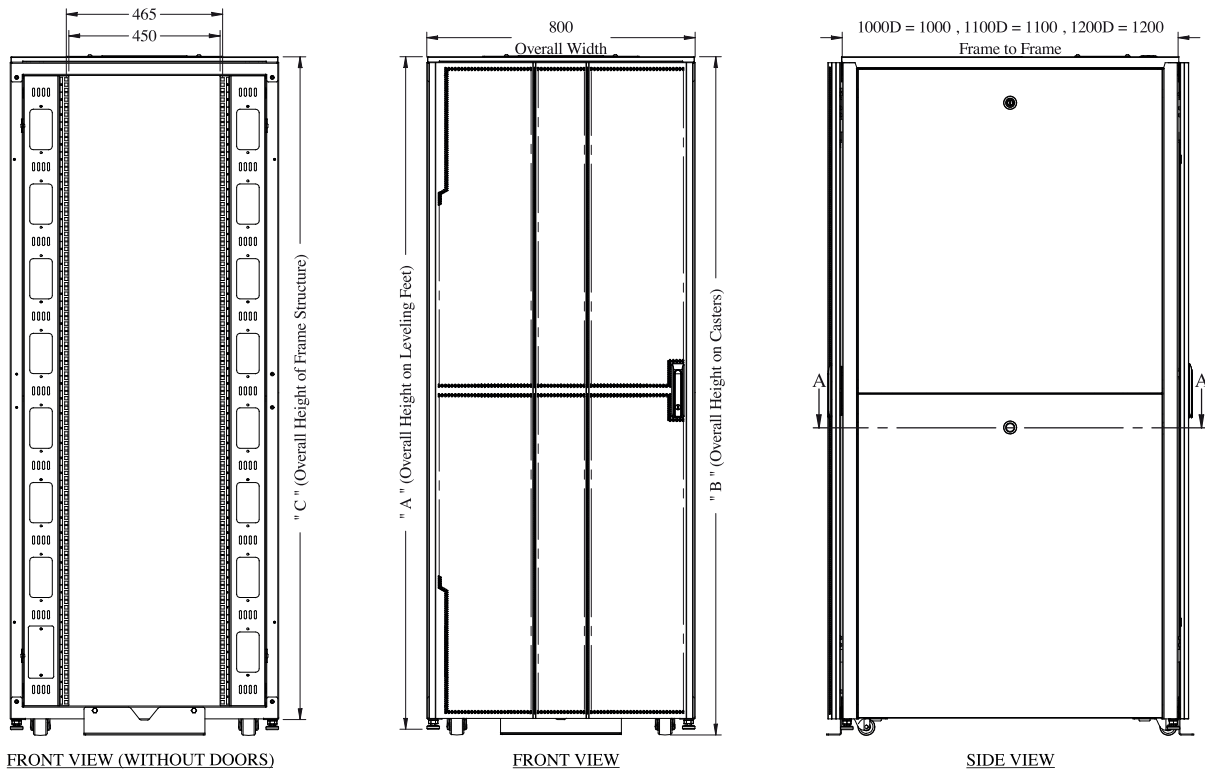

DIMENSIONS (UNIT : MM)			
UNIT HEIGHT	DIM. "A"	DIM. "B"	DIM. "C"
42U	2003	2020	1973
45U	2136	2153	2106





www.chevalgrp.com