

Cheval



Cheval Electronic Enclosure Co., Ltd.
Corporate Headquarters and Manufacturing
Located near Bangkok, Thailand.

Cheval Electronic Enclosure Co., Ltd.
(Thailand Sales office)

Thailand sales and distribution for Cheval
branded products.

11 MD Tower, Ground Floor, Zone B, Soi Bangna-Trad 25,
Khwang Bangna, Khet Bangna, Bangkok 10260 Thailand

E-Mail : domestic_sales@chevalgrp.com

Tel no : +66 2744 1632



Cheval Technology Co., Ltd. : Groups main manufacturing site for Cheval branded 19" Cabinets.



AegisTek Corporation Ltd. : Groups main manufacturing site for large OEM clients.

Cheval Electronic Enclosure Company Limited

Contact Information : 145 Bangplee Industrial Estate, Soi 4, Moo 17, Bangsaotong Samutprakarn 10540, Thailand.

Telephone no: +66 2315 1504-5, +66 2315 2263-5 Fax no: +66 2315 1506 , +66 2705 1006

Email: commce@chevalgrp.com www.chevalgrp.com www.facebook.com/chevalgrp



Cheval

Global Leader In 19" Enclosure
and Infrastructure Support

PRODUCTS AND SERVICES

CHEVAL
www.chevalgrp.com

Cheval Group

For more than 30 years the Cheval Group has focused on providing high quality cost effective electronic and 19 inch enclosure solutions to our partners around the globe. During this journey, we have continued to improve our people, products, and processes.

We have grown from a single, small manufacturing facility to a globally recognized leader in design and manufacturing of standard and customized 19" Enclosure Systems, Industrial and Outdoor Enclosures and custom electronic enclosures.

We have delivered hundreds of thousands of 19" enclosures to our multinational clients to locations around the globe. Our main markets are:

- Colocation and Cloud Data Center Providers
- Network and Structured Cabling Providers
- Telecommunications and Media Content Providers
- Electronic Manufacturing Services Providers (EMS)

However, past success does not guarantee our clients' future satisfaction. Cheval will constantly challenge ourselves to be a leader in technical innovation of our products and just as important, continue our development as a socially responsible corporation managed under internationally accepted good governance principles.

1980
Cheval Electronic Enclosure Co.,Ltd. (CE) began development of product concepts.

1981
Start of manufacturing operations. Five employees and a shop house.

1982
Moved to 400 square meters factory and increased employees to 30 persons.

1986
New share holding structure with individual and corporate investors joining the group

1987
Opening of 5,000 square meters facility in Bangplee Industrial Estate. Change production system from hand made to internationally recognized production control process. First company in Thailand using CNC Turret Press, NC bending machine and Computer Aided Manufacturing (CAM)

1989
Change in share holding structure with Amtek Engineering of Singapore, a public listed firm joining team. Opened Tool Room and Metal Stamping Facility.

1996
Construction of Cheval Technology (CT), a 4,000 square meters dedicated rack manufacturing facility in Chiang Mai, northern Thailand.

1997
Purchase of Mail Scientific Electronics Co.,Ltd. (MSE) to handle local sales and marketing activities.

1998
Start large volume shipments of 19" Cabinets to the USA. Introduction of "Aegis" line of 19" Cabinets.

1999
Cheval Electronic receives ISO 9002 Certification.

2001
Introduction of "Cyberack" line of 19" cabinets. First data center project in Thailand, for I-STT group.

2002
Cheval Technology receives ISO 14001 certification.

2004
Construction of AegisTek Corp begins.

2005 
AegisTek Corp comes on line. Cheval Group achieves one billion Baht sales. First NEBS GR-63 Core seismic zone 4 cabinet designed and produced for a USA multinational client.

2007
"Atlas", Cheval own brand 19" Seismic cabinet is certified Zone 4 in the United States. Design and certification of Zone 4 seismic cabinet for Comverse of Israel. All three Cheval facilities certified to ISO 9001:2000 and ISO 14001. Addition of 19" colocation enclosures to product line.

2009
Reincorporation of Mail Scientific Enclosures into Cheval Electronic as domestic sales office and logistics center. Joined United Nations "Global Compact"  to support increased corporate social responsibility.

2010
Mark shipment of over 300,000 racks since opening of AegisTek Corp. Introduction of "Arion" Series, our first patented 19" cabinet design. Expansion of market at Cheval Electronics for local EMS clientele. Successful certification of our fifth Zone 4 seismic cabinet; this for a major USA multinational client.

2011
Reentry into Outdoor Enclosures market, with both local and international projects fulfilled. AegisTek certified to ISO 9001:2008 and ISO 14001:2004.

2012
Launch of Cold Aisle Containment products. Cheval Technology certified to ISO 9001:2008 and ISO 14001:2004. AegisTek receives first "Best Corporate Governance (Northern Region)" award from Thailand's National Anti Corruption Commission.

2013
AegisTek and Cheval Technology receive "Best Corporate Governance (Northern Region)" award from Thailand's National Anti Corruption Commission. AegisTek ships 400,000th cabinet since opening.

2014 
"Arion" 19" cabinet next generation upgraded line receives UL listing. Development of Intelligent Power Distribution Units (PDU) product line commences. AegisTek and Cheval Technology again receive "Best Corporate Governance (Northern Region)" award from Thailand's National Anti Corruption Commission.



End to End Solutions for your Enclosures Needs

The Cheval group has established a global reputation as a leader in design and manufacturing of EIA-310 standard 19 inch enclosures for the OEM and ODM markets. While our core competency is in the 19 inch market, a significant part of our operations are dedicated to Outdoor cabinets and the fabrication plus integration of general metal enclosures and chassis for the electronics and IT markets.



We provide complete in house manufacturing service and support. Starting with CNC turret punching, CNC bending, robotic welding and grinding followed by top quality powder paint and concluding with mechanical assembly, packing and logistic support to your final destination.



Quality Assurance - For Your Peace of Mind

Quality is our top concern and we have certified all three of our facilities to the latest quality standards of ISO 9001:2008 and 14001:2004. However, we recognize that these international standards are not as important as our clients continued satisfaction with our service and products. We constantly strive to exceed their expectations and targets, which are much more exacting benchmarks than achieving third party certifications.

RD&D and Engineering Support – For Your Benefit

Research Design and Development are the cornerstones to our long term success. Our RD&D teams perform a variety of roles to maximize their output. Cheval's Product Development RD&D team stays on top of the latest developments in the IT world to ensure we stay ahead of the trend. The team continuously develops our Cheval brand 19" family of products and can work with you to develop a product from the ground up or just provide partial design support. We have developed over 175 products with 6 patents pending for 19" racks. Our Manufacturing Improvement RD&D team constantly develops and improves our manufacturing process and efficiency. In addition to driving costs out of the final product, the team has designed and implemented several innovative testing and load rating stations and methodologies. This allows us to verify all specifications for new products. Our engineering team provides strong new product introduction (NPI) support, working closely with our clients and related departments in Cheval.



Manufacturing Muscle and Redundancy

Our three production sites, controlled by our corporate headquarters in Bangkok, are all equipped with the latest manufacturing technology and equipment. We blend automation with the human touch, resulting in high quality, cost effective solutions for you. More importantly, all sites follow the same process and quality control systems, thus giving us the ability to allocate additional capacity when needed.

Our combined facilities have capacity to produce about 10,000 cabinets of various configurations per month. We ship both assembled and flat packed. Our three manufacturing sites cover some 118,500 sq. meters (about 1,275,000 sq. feet), currently with production space of 24,200 sq. meters (about 260,500 sq. feet) available for you.



Cheval Electronic Enclosure (Bangkok)



Thailand Sales Office (Bangkok)



Cheval Technology (Chiangmai)



AegisTek Corporation (Chiangmai)



Standard Enclosures



Special Application Enclosures



Free Standing Open Racks



Wall Mount



Stand Alone Electronic Enclosures



Power Distribution and Accessories



Industry Segments	Products	Series	Page
Data Center	Server Cabinet	Arion 600 Series	08 to 11
Network and Telecoms	Networking Cabinet	Arion 800 Series	12 to 13
Data Center	Colocation Cabinet	2 Door 3 Door 4 Door	14 to 15
	Seismic Cabinet	Atlas	16 to 17
Network and Telecoms	Open Rack	2 Post 4 Post	18 to 19
Office Solutions	19" Wall Mounted Enclosures and Frames Patch Panels	WallNet Wall Mount Open Frame	20 to 21 22
Industrial and Home Use	Stand Alone Desk Top and 19" Rack Mounted	SA Series PF-19 Series	23 to 24
All	Accessories	PDU, Shelves, Panels, Cable Management, Hardware	25 to 29





ARION : Innovative 19" Enclosure Solutions

The Arion Series is the latest line of feature rich innovative 19" enclosures which Cheval has designed. The UL listed Arion platform offers the user a vendor neutral enclosure which fulfills a wide range of applications in the ITC and Data Center market. Working off the Arion platform, our design teams can customize the enclosure to meet your precise requirements.



600 wide series

Light but Strong

Our unique design results in a light weight, but very strong enclosure. Arion series racks are UL listed to 1,400 kg. At the same time, the weight of the complete enclosure has been kept down through innovative use of materials and manufacturing techniques.

Safety and Security

All components in the Arion cabinet are electrically grounded for user safety as per UL requirements. All doors and side panels are equipped with locks. We offer standard swing handles, combination locks and half profile locks. Security panels for bayed enclosures are also available.

Flexibility

Most 19" enclosures are provided configured complete with all panels, doors, casters and so on. We let you choose the exact configuration you need, to ensure you get the product you need, and more importantly, not pay for components not needed. All doors are left-right reversible by the user on location. Arion enclosures can be bayed together at time of installation, or sometime in future, providing the user with expansion capability to match their needs.

Logistics Efficiency

Arion's knock down design allows for up to 128 complete enclosures to be bulk packed into one ocean going 40' container. Arion can easily be assembled in less than 20 minutes by two operators. Cheval provides bulk packed, kitted or assembled configurations to provide additional logistic options, depending on the user and location. With our "Four Pack" kits, you can easily do assembly on site. Arion does not require any special jigs or fixtures to assemble.



800 wide series

Arion Technical Specifications Summary

Arion 600 Series	800 Deep				1000 Deep				1200 Deep		
	27U	42U	45U	47U	27U	42U	45U	47U	42U	45U	47U
Overall Height of Rack without Casters (mm)	1299	1966	2099	2188	1299	1966	2099	2188	1966	2099	2188
Overall Height of Rack including Casters (mm)	1327	1994	2127	2216	1327	1994	2127	2216	1994	2127	2216
Overall Depth, Door to Door	890	890	890	890	1090	1090	1090	1090	1290	1290	1290
Rack Depth, Frame to Frame	800	800	800	800	1000	1000	1000	1000	1200	1200	1200
Usable Rack Height	27U	42U	45U	47U	27U	42U	45U	47U	42U	45U	47U
Net weight (Kg.) (Include Caster)	78	104	110	115	79	110	116	120	129	137	141
Maximum Mounting Depth (mm)	690	690	690	690	890	890	890	890	1090	1090	1090
Front Door Total Open Area (sq in)	654	1032	1109	1160	654	1032	1109	1160	1032	1109	1160
Rear Door Total Open Area (sq in)	656	1008	1074	1122	656	1008	1074	1122	1008	1074	1122
Door opening Radius (degrees)	155°	155°	155°	155°	155°	155°	155°	155°	155°	155°	155°

Arion 800 Series	800 Deep				1000 Deep				1200 Deep		
	27U	42U	45U	47U	27U	42U	45U	47U	42U	45U	47U
Overall Height of Rack without Casters (mm)	1299	1966	2099	2188	1299	1966	2099	2188	1966	2099	2188
Overall Height of Rack including Casters (mm)	1327	1994	2127	2216	1327	1994	2127	2216	1994	2127	2216
Overall Depth, Door to Door	890	890	890	890	1090	1090	1090	1090	1290	1290	1290
Rack Depth, Frame to Frame	800	800	800	800	1000	1000	1000	1000	1200	1200	1200
Usable Rack Height	27U	42U	45U	47U	27U	42U	45U	47U	42U	45U	47U
Net weight (Kg.) (Include Caster)	82	110	116	120	88	122	128	132	147	155	159
Maximum Mounting Depth (mm)	690	690	690	690	890	890	890	890	1090	1090	1090
Front Door Total Open Area (sq in)	867	1446	1546	1617	867	1446	1546	1617	1446	1546	1617
Rear Door Total Open Area (sq in)	926	1423	1515	1582	926	1423	1515	1582	1423	1515	1582
Door opening Radius (degrees)	155°	155°	155°	155°	155°	155°	155°	155°	155°	155°	155°





The Arion 600 Series combines strength, light weight and superior air flow making it well suited for most installations, such as high density server configurations as found in data centers. Arion is vendor neutral and will accommodate any standard 19" equipment. For networking and structured cabling configurations, please refer to our Arion 800 Series.



Solid doors available

Our Standard Configurations

Arion is a very flexible 19" enclosure platform, which can be customized to meet your requirements. Our standard offerings are based on configurations which have the highest demand. If what you need is not part of our "standard", please contact us for further information.

- Color: Low gloss textured black
- Frame to Frame Depth: 800, 1,000 and 1,200 millimeters
- Height: 27, 42, 45 and 47U. Additional sizes starting from 15U available upon request.
- Packing can be bulk packed, assembled or kitted.

Industry Standards and Materials

- UL 2416 Issue No. 2 and CSA C22.2 No. 60950-1-07 Second Edition
- Dimensions conform to EIA-310E and IEC-60297-1, -2.
- Premium grade galvanized, hot and cold rolled steel.
- Designed and manufactured under ISO 9001:2008 and ISO 14001:2004 Five stage iron-phosphate pretreatment with powder coat finish.
- Tested to 500 hours salt spray under ASTM-D610-01 and ASTM-B117.
- All materials RoHS compliant.
- Patents pending: 1002000994, 1001000784, 1001000785, 1001000786, 1001000787 and 1301005921

Optional code lock handles available



Features

-  UL listed for static load rating of 1,400 kg.(3,080 lbs) and electrical grounding.
- Contoured door with high density perforation pattern exceeds 80%, more than 1,000 sq inches, open area (based on 42U high).
- High quality construction.
- Cost effective solution.
- Open base for maximum cable entry.
- Knock down design for convenient shipping and storage
- Quick and easy assembly, needs two operators and 15 minutes per enclosure
- Leveling feet allow precise alignment at installation site.
- Split level side panels for convenient access to installed equipment.
- 19" vertical mounting rails depth adjustable in 6.35mm increments.
- High contrast labels on horizontal members for easy 19" rail alignment.
- "U" numbers printed on 19" vertical rails.
- All doors use quick release hinges and are field reversible.

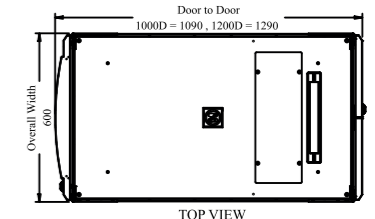
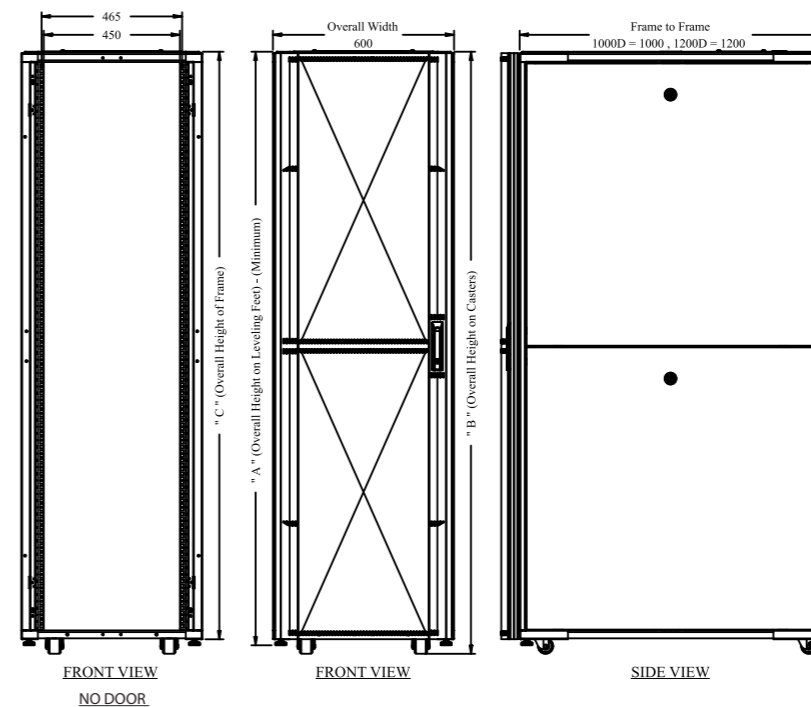

Standard Cabinet Configuration

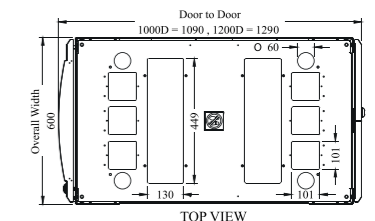

HD Cabinet Configuration

DIMENSIONS (UNIT : MM)			
UNIT HEIGHT	DIM. "A"	DIM. "B"	DIM. "C"
27U	1299	1327	1279
42U	1966	1994	1946
45U	2099	2127	2079
47U	2188	2216	2168





The Arion 800 Series is designed for networking and high density cabling environments. The 800 mm wide enclosures provide more than adequate space for Structured Cabling, Network and Telecoms needs. Cable management features combined with the enclosure design allows for installation and organization of non standard size equipment and variety of related products.



Features

- **cUL^{us} LISTED** UL listed for static load rating of 1,400 kg.(3,080 lbs) and electrical grounding.
- Contoured door with high density perforation pattern exceeds 80%, more than 1,000 sq inches, open area (based on 42U high).
- Extensive area for cabling inside the enclosure.
- Multiple openings for cable access on top.
- Brush strips and air block kits available for proper air flow management.
- High quality construction.
- Cost effective solution.
- Open base for maximum cable entry.
- Knock down design for convenient shipping and storage
- Quick and easy assembly, needs two operators and 25 minutes per enclosure
- Leveling feet allow precise alignment at installation site.
- Split level side panels for convenient access to installed equipment.
- 19" vertical mounting rails depth adjustable in 6.35mm increments.
- High contrast labels on horizontal members for easy 19" rail alignment.
- "U" numbers printed on 19" vertical rails.
- All doors use quick release hinges and are field reversible.



Split Side Panels offer easy access

Our Standard Configurations

Arion is a very flexible 19" enclosure platform, which can be customized to meet your requirements. Our standard offerings are based on configurations which have the highest demand. If what you need is not part of our "standard", please contact us for further information.

- Color: Low gloss textured black
- Frame to Frame Depth: 800, 1,000 and 1,200 millimeters
- Height: 42, 45 and 47U. Additional sizes available upon request.
- Packing can be bulk packed, assembled or kitted.

Industry Standards and Materials

- UL 2416 Issue No. 2 and CSA C22.2 No. 60950-1-07 Second Edition
- Dimensions conform to EIA-310E and IEC-60297-1, -2.
- Premium grade galvalume, hot and cold rolled steel.
- Designed and manufactured under ISO 9001:2008 and ISO 14001:2004 Five stage iron-phosphate pretreatment with powder coat finish.
- Tested to 500 hours salt spray under ASTM-D610-01 and ASTM-B117.
- All materials RoHS compliant. 
- Patents pending: 1002000994, 1001000784, 1001000785, 1001000786, 1001000787 and 1301005921

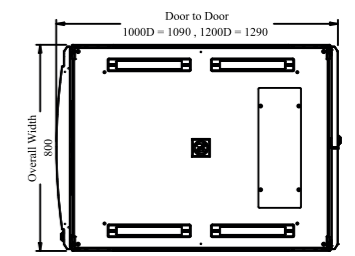
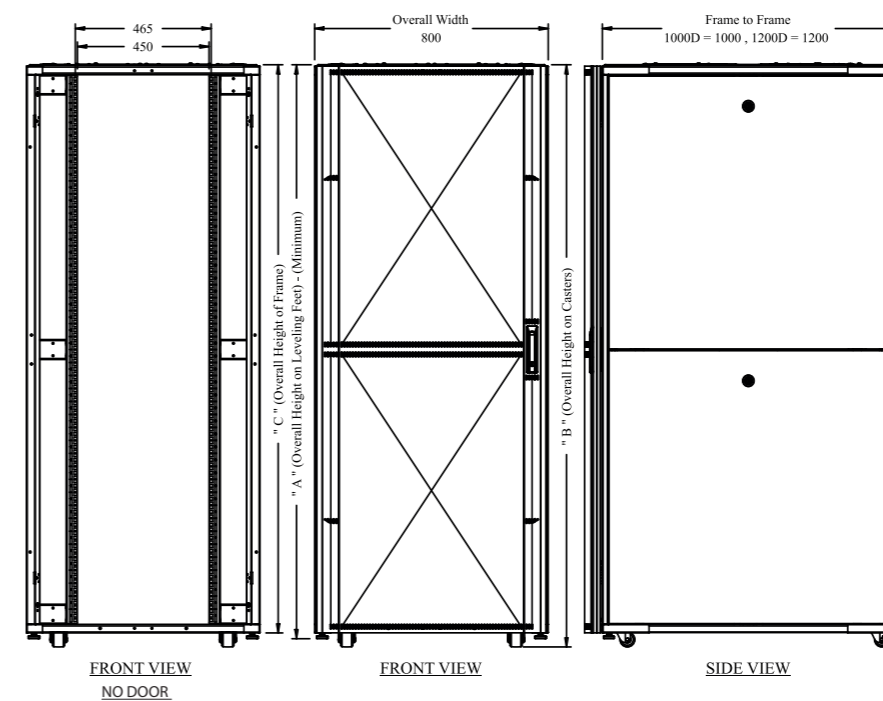

TOP VIEW
Standard Cabinet Configuration

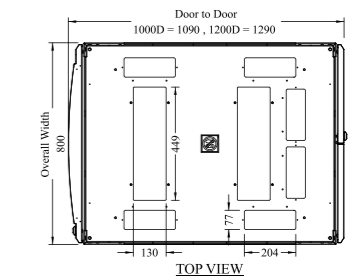

TOP VIEW
HD Cabinet Configuration

DIMENSIONS (UNIT : MM)			
UNIT HEIGHT	DIM. "A"	DIM. "B"	DIM. "C"
27U	1299	1327	1279
42U	1966	1994	1946
45U	2099	2127	2079
47U	2188	2216	2168





The Arion Solis 600 Series is designed for the small business environment and low density server installations, it is a cost effective solution providing most features found in premium racks, without compromising on quality. A load capacity of 1,000 kg. is more than enough to support the mixed equipment installations common to most IT rooms. Our user friendly design will accept standard 19" equipment from any vendor and provide the perfect solution to organizing for your IT equipment.

Technical Specifications Summary

Cabinet Model	1000 Deep		1100 Deep		1200 Deep	
	42U	45U	42U	45U	42U	45U
Overall Height of Rack including Casters	2020	2153	2020	2153	2020	2153
Overall Depth, Door to Door	1065	1065	1165	1165	1265	1265
Rack Depth, Frame to Frame	1000	1000	1100	1100	1200	1200
Usable Rack Height	42U	45U	42U	45U	42U	45U
Net Weight (Kg.) (Include Casters)*	113	118	118	123	123	128
Maximum Mounting Depth (mm)	929	929	1029	1029	1129	1129
Single Door Total Open Area (sq in), all exceed 80%	1055	1132	1055	1132	1055	1132
Double Door Total Open Area (sq in), all exceed 80%	1014	1080	1014	1080	1014	1080
Door Opening Radius	132°	132°	132°	132°	132°	132°

Features

- Cost Effective
- Static load rate 1,000 kg.
- Contoured high density perforated door exceeds 80% open area
- Knock down design for efficient shipping
- Up to 160 sets per 40' container (bulk pack)
- Light weight
- Split level side panels provide convenient access to installed equipment
- Depth adjustable 19" vertical mounting rails in 20 mm increments
- Quick assembly time, approximately 20 minutes
- Quick release lift off doors
- Field reversible doors
- Multiple sizes available
- Flexible packing methods allows for convenient stocking and end user delivery

Standards and Materials Summary

- Dimensions conform to EIA-310E, IEC-60297-1, 2
- Five stage iron-phosphate pretreatment with textured powder coat finish, tested to 500 hours
- salt spray under ASTM-D610-01 and ASTM-B117
- Standard color is low gloss textured black
- Premium grade Hot and Cold rolled steel sheet
- Designed and Manufactured under ISO 9001:2015 and ISO 14001:2015
- All materials RoHS compliant

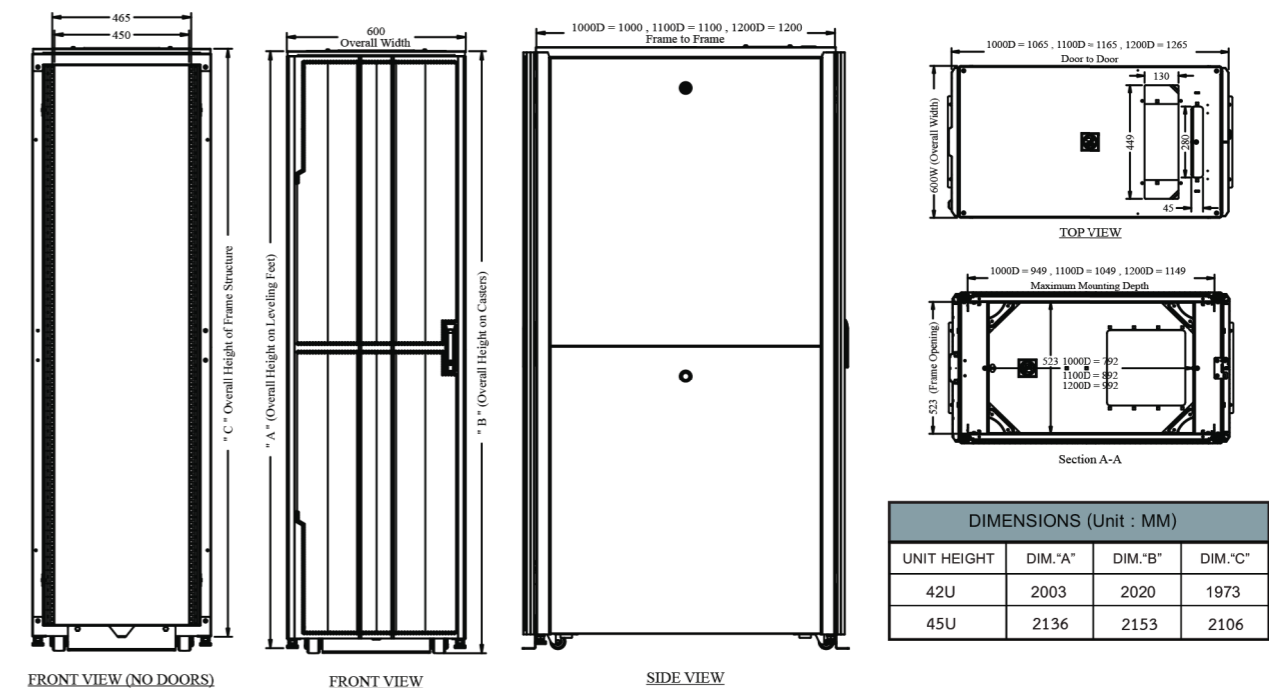

DIMENSIONS (Unit : MM)			
UNIT HEIGHT	DIM."A"	DIM."B"	DIM."C"
42U	2003	2020	1973
45U	2136	2153	2106



Arion Solis 800 Series is designed for both large and small networking deployments. Primarily for networking and structured cable installations, Solis is also ideally suited for mixed IT environments using networking, server, storage and other IT gear.



Technical Specifications Summary

Cabinet Model	1000 Deep		1100 Deep		1200 Deep	
	42U	45U	42U	45U	42U	45U
Overall Height of Rack including Casters	2020	2153	2020	2153	2020	2153
Overall Depth, Door to Door	1065	1065	1165	1165	1265	1265
Rack Depth, Frame to Frame	1000	1000	1100	1100	1200	1200
Usable Rack Height	42U	45U	42U	45U	42U	45U
Net Weight (Kg.) (Include Casters)*	109	114	113	118	118	123
Maximum Mounting Depth (mm)	929	929	1029	1029	1129	1129
Single Door Total Open Area (sq in), all exceed 80%	1466	1571	1466	1571	1466	1571
Double Door Total Open Area (sq in), all exceed 80%	1397	1488	1397	1488	1397	1488
Door Opening Radius	132°	132°	132°	132°	132°	132°

Features

- Extra width for convenient internal cable routing and thermal management
- Cable access through top or base
- 1,000 kg. load capacity
- Contoured high density perforated door exceeds 80% open area
- Vendor neutral, accepts any 19" standard rack mounted product
- Light weight and strong.
- Split level side panels provide convenient access to installed equipment.
- Depth adjustable 19" vertical mounting rails in 20 mm increments
- "U" numbers printed on 19" rails.
- Knock down design for efficient shipping.
- Up to 120 sets per 40' container (bulk pack)
- Quick assembly time, approximately 20 minutes.
- Lift off door type for quick release
- Field reversible doors.
- Flexible packing methods allows for convenient stocking and end user delivery.

Standards and Materials Summary

- Dimensions conform to EIA-310E, IEC-60297-1, 2
- Five stage iron-phosphate pretreatment with textured powder coat finish, tested to 500 hours
- salt spray under ASTM-D610-01 and ASTM-B117
- Standard color is low gloss textured black
- Premium grade Hot and Cold rolled steel sheet
- Designed and Manufactured under ISO 9001:2015 and ISO 14001:2015
- All materials RoHS compliant

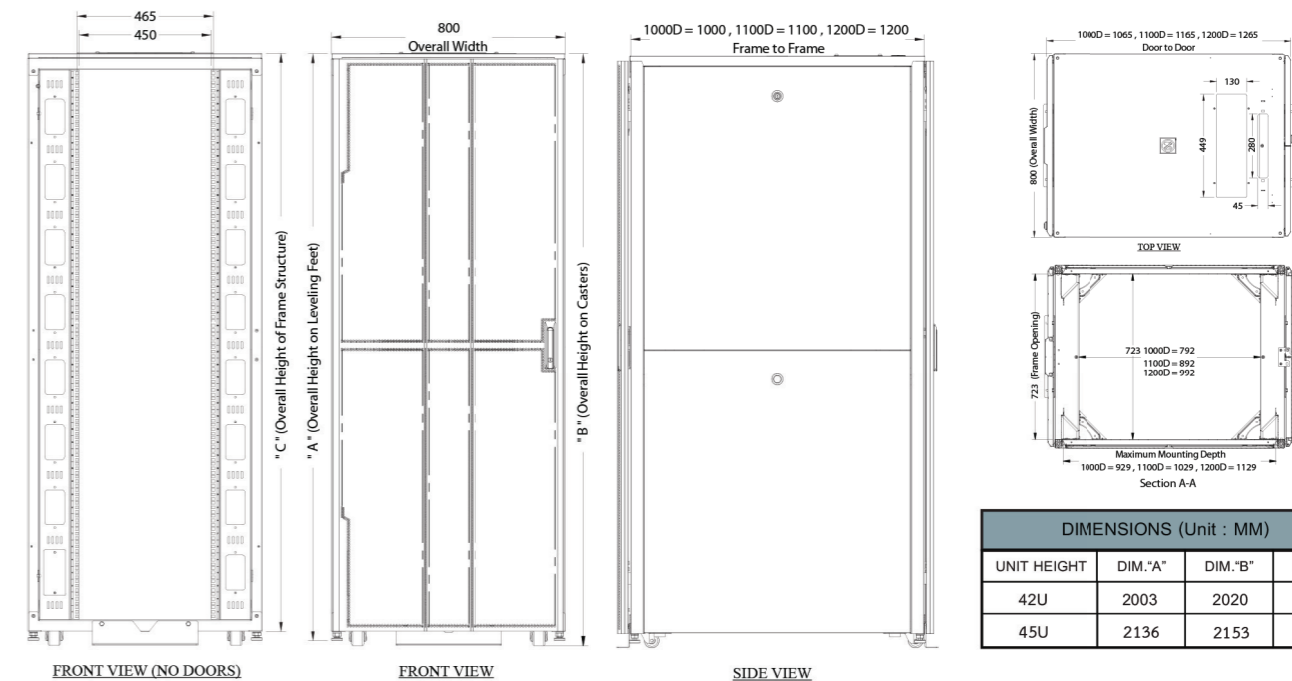



Cheval is a member of
OCP Community.



Technical Specifications Summary

- Rack Inner space – 41 OU
- Form Factor - 21" Open Compute Rack
- Rack total height – 2210 mm
- Rack total width - 600 mm
- Rack total depth – 1067 mm
- Rack weight w/ 3 bus bars – 199.6 KG (no equipment)
- Designed and Manufactured under ISO 9001: 2015 and ISO 14001:2015
- All materials RoHS compliant 
- Five stage iron-phosphate pre-treatment with textured powder coat finish, tested to 500 hours salt spray under ASTM-D610-01 and ASTM-B117

Cheval has been designing and manufacturing EIA standard 19" racks for over 30 years. We are now taking this experience and developing an OCP Open Rack, based on Facebook's Singlet Open Rack V2. We have maintained all the key features of the rack while making a knock-down version to maximize shipping and storage efficiency.

Features

- Based on Facebook Open Rack V2 specifications.
- Knock down configuration can load 84 complete racks per 40' container.
- Assembled configuration can load 27 racks per 40' container.
- Triple bus bar power architecture.
- 41 OU overall internal mounting space.
- U numbers marked for convenient equipment installation.
- Up to 2 power zones utilizing 2 x 3 OU power shelves.
- IT Support Brackets
- Heavy duty swivel leveling feet and casters
- Supports 1400 KG load
- Overall footprint 600mm x 1067mm.
- Optional EIA 19" adapter kits available
- Optional side panels and doors available
- Customization requests welcome





The Colocation Series provides a secure and highly versatile solution for facilities that offer colocation services.

Available in 2, 3 or 4 compartment configurations, our Colo enclosure provides complete integrity between compartments, plus optimized cable and air management. Standard swing handles can be ordered with different key numbers and optional code lock swing handles are also available.

Features

- Individual compartments sealed and accessible only to individual user
- Depth adjustable 19" mounting rails
- Field reversible doors with 135 degree opening radius
- High density perforated doors with provision to mount fan on rear door
- Optional security panel replaces standard side panel when two or more enclosures are bayed together
- Optional 3 digit code lock or profile cylinder swing handles for additional security

Optional code lock handles available



Our Standard Configurations

- Arion colocation series is available in 600 mm wide by 1000 mm deep at 42U height.
- Color: Low gloss textured black
- Packing can be bulk packed, assembled or kitted.

Industry Standards and Materials

- Dimensions conform to EIA-310E and IEC-60297-1, -2.
- Premium grade hot and cold rolled steel.
- Designed and manufactured under ISO 9001:2008 and ISO 14001:2004
- Five stage iron-phosphate pretreatment with powder coat finish.
- Tested to 500 hours salt spray under ASTM-D610-01 and ASTM-B117.
- All materials RoHS compliant.



Colocation Cabinets : Dimension overview

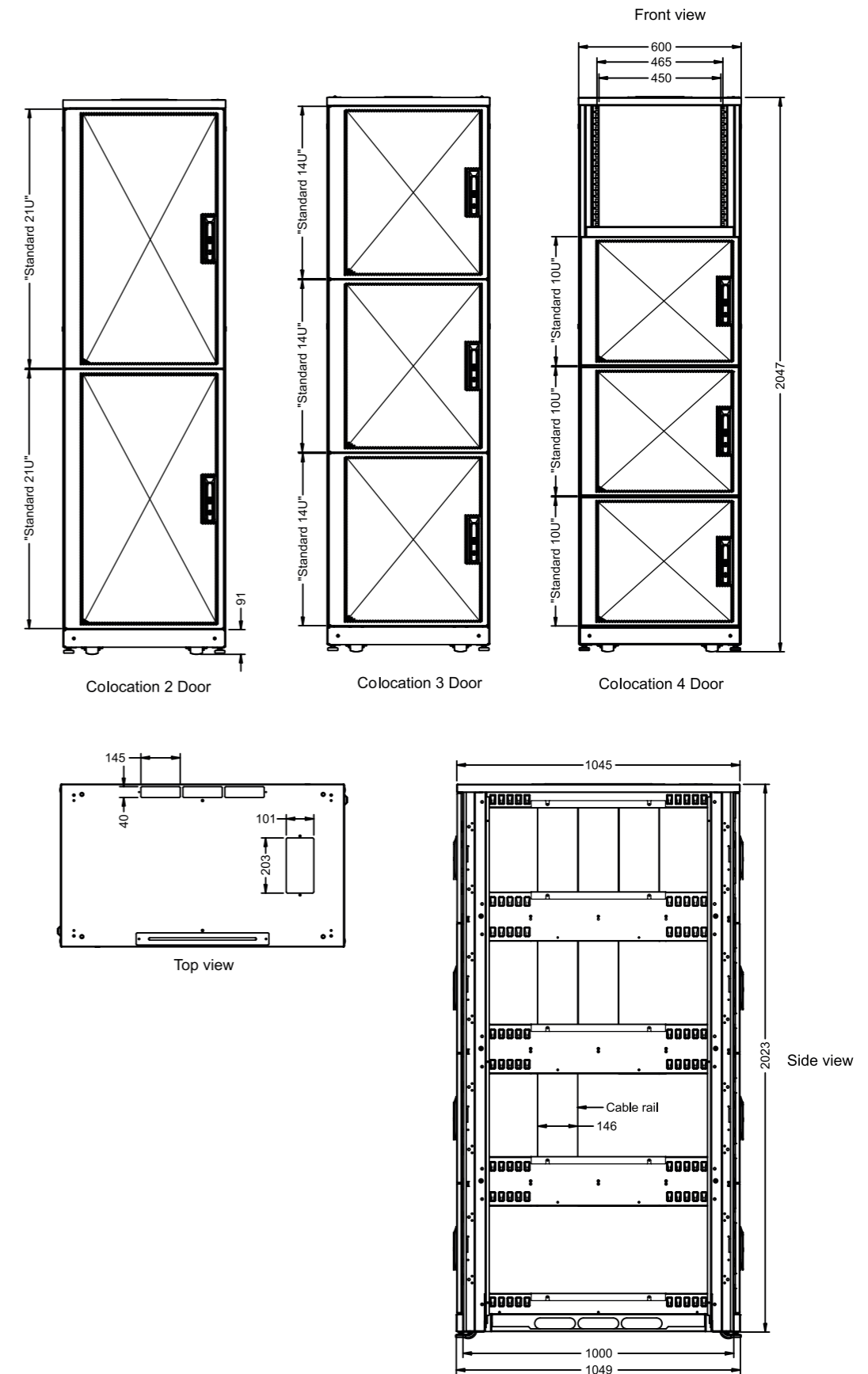



Our Atlas Seismic enclosure is a NEBS Zone 4 certified rack for extreme load conditions. The fully welded frame structure has been seismically tested and confirmed to support 550 KG (1,210 lbs) under the exacting requirements of GR-63-CORE. In addition to its proven strength, Atlas provides an ample 1,000 mm depth for equipment installation and over 1,000 sq. inches open area for air flow.

Features

- Fully welded frame construction.
- Massive 550 KG (1,210 lbs) certified seismic load rating.
- Adjustable 19" vertical mounting rails
- "U" markings on rails for convenient equipment installation
- Multiple access openings on top panel for cabling.
- Open base provides easy access for cables
- Stylish curved front door is reversible and provides over 1,000 sq. inches open area.
- Split rear doors reversible.
- ESD grounding point embedded in frame.

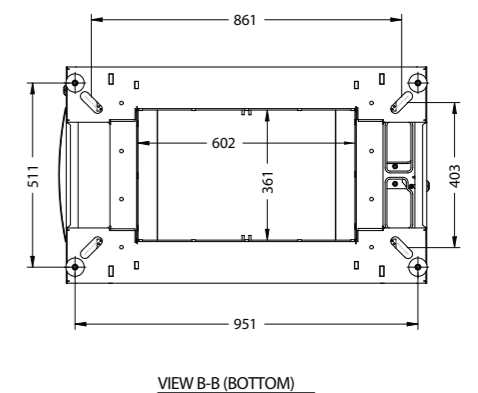
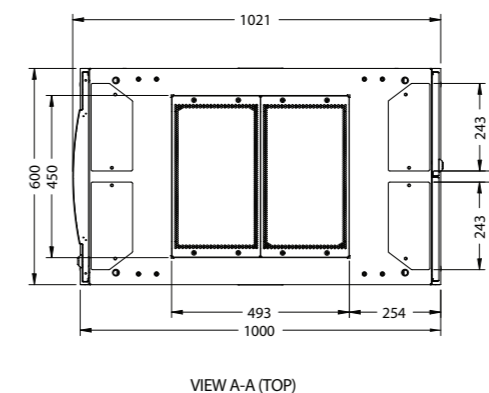
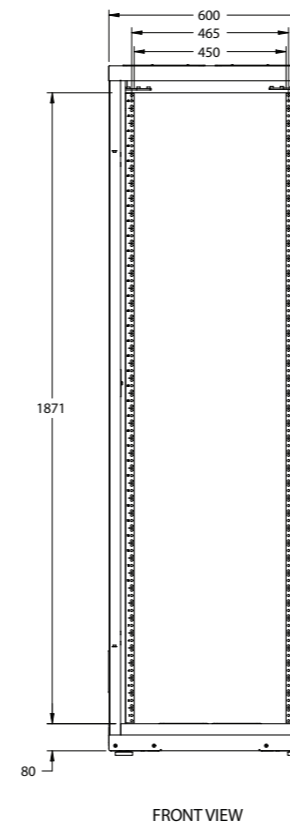
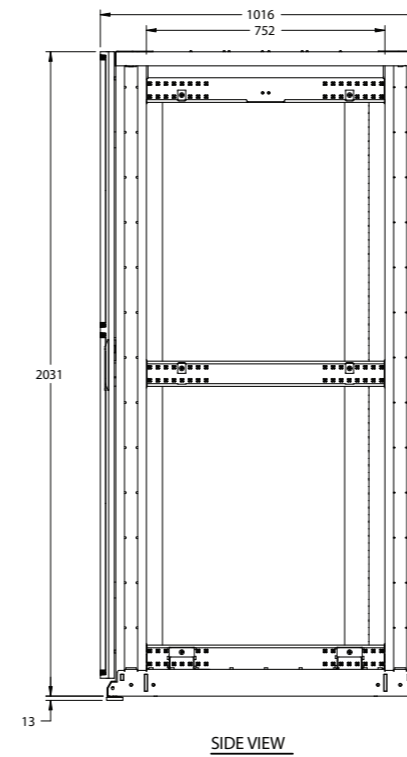

Our standard configurations

- Our standard Atlas platform has been officially certified by Metlabs, USA.
- Other configurations are possible, and due to industry testing requirements, may need to be retested by third party certification firm. Please inquire for specifics.
- Atlas is available in 600 mm wide by 1,000 mm deep and 42U high.
- Standard color is low gloss black
- Atlas ships fully assembled on pallet.

Industry Standards and Materials

- NEBS Telcordia GR-63-CORE
- ANSI T1.329-2002 and T1.336-2003
- Dimensions conform to EIA-310E and IEC-60297-1, 2.
- Premium grade hot and cold rolled steel.
- Designed and manufactured under ISO 9001:2008 and ISO 14001:2004
- Five stage iron-phosphate pretreatment with powder coat finish.
- Tested to 500 hours salt spray under ASTM-D610-01 and ASTM-B117.
- All materials RoHS compliant. 



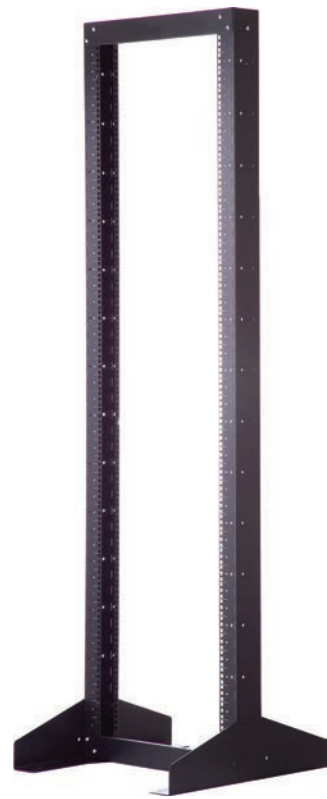

Our Open Frame Rack Series is a cost and space effective way to install a variety of 19" equipment. Intended primarily for patch panels or network switching equipment, we offer two and four posts versions.

Features

- Sturdy all steel construction
- "U" marks printed on rails.
- Square 9.50mm holes accept standard caged nuts.
- Bolts directly to floor
- Optional shelves for two post version
- Four post version can use casters to be free standing on floor.
- Four post version depth adjustable

Our Standard Configurations

- Available in two or four post versions
- Heights : 39, 42 and 45U
- Color: Low gloss textured black
- Packing can be bulk packed or kitted.

Industry Standards and Materials

- Dimensions conform to EIA-310E and IEC-60297-1, 2.
- Premium grade hot and cold rolled steel.
- Designed and manufactured under ISO 9001:2008 and ISO 14001:2004
- Five stage iron-phosphate pretreatment with powder coat finish.
- Tested to 500 hours salt spray under ASTM-D610-01 and ASTM-B117.
- All materials RoHS compliant. 

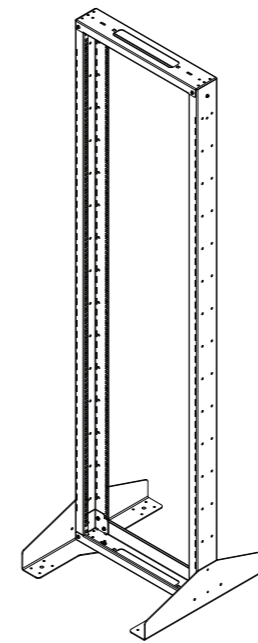
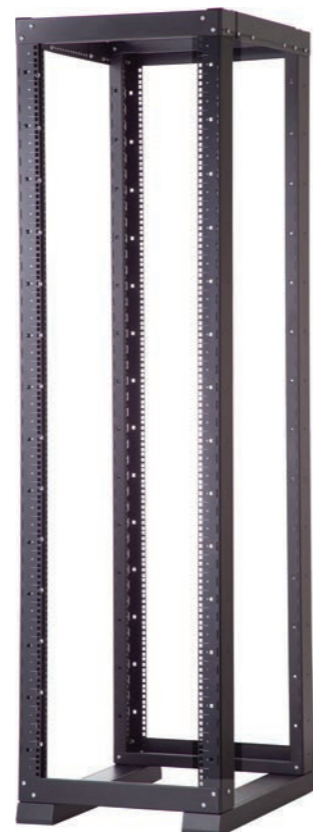

MODEL	REF. "A"	REF. "B"
39U	1867	1737
42U	2000	1870
45U	2134	2003

Dimension in mm.

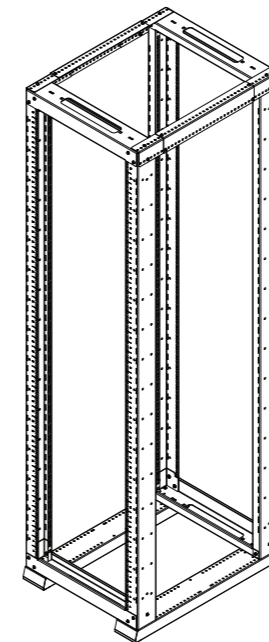
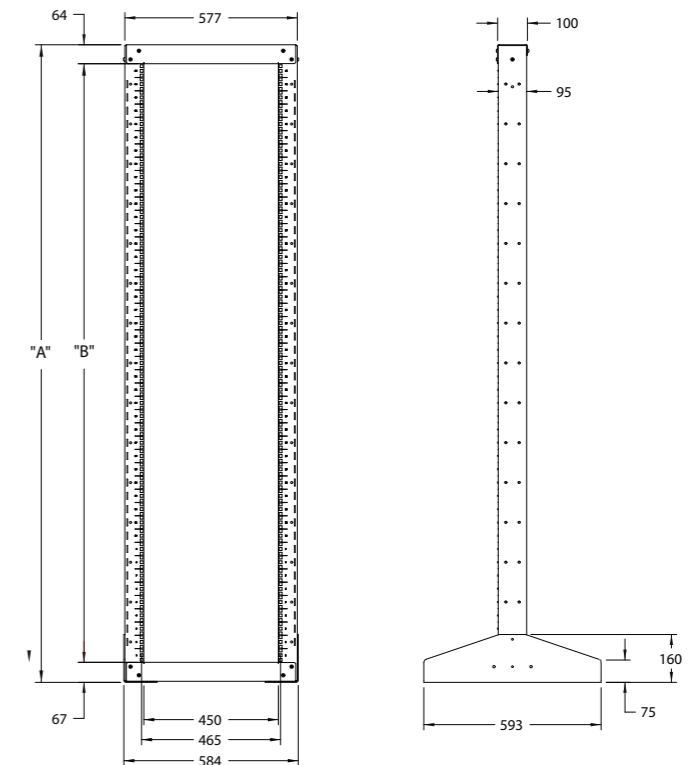

MODEL	REF. "A"	REF. "B"
39U	1919	1737
42U	2053	1870
45U	2186	2003

Dimension in mm.

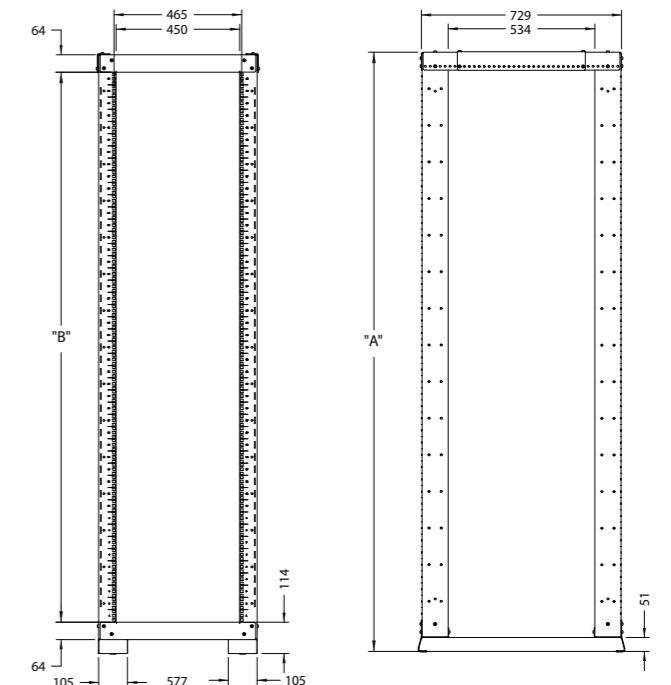



Standard WallNet



WallNet with extension kit



Our WallNet Series of 19" wall mounted enclosures offer a sturdy and secure enclosure in a compact package. Ideal for remote installations of routers, switches, UPS and patch panels.

Features

- Vendor neutral will accept any standard 19" mounted device.
- Integrated 19" mounting rails incorporated into adjustable inner frame for extra strength.
- Two cable entry slots on the top and bottom of the enclosure.
- Knock down design.
- Simple installation using template for locating mounting points on wall.
- Reversible door allows flexibility at installation site.
- Supports loads up to 120 kg. for standard wall box.
- Supports loads up to 35 kg. with extension kit.

Extension Kits: (Optional component)

Expand the functionality of the WallNet with our extension kits. These kits, available in 140 mm depths provide both extra depth plus convenient access to the rear of the cabinet. The extension frame is first installed in the preferred location. The basic wall box is then installed using the lift off hinges, either left or right hand oriented. This convenient lift off hinge allows a single person to handle the installation

Our Standard Configurations

- Color: Low gloss textured black
- Depth: 500 mm deep (6U version is 350 mm deep)
- Depth Extension Kits: 140 mm.
- Width: 600 mm external
- Height: 6, 9, 12, and 18U. Additional sizes available upon request.
- Packing: Bulk packed, flat pack kitted or assembled

Industry Standards and Materials

- Dimensions conform to EIA-310E and IEC-60297-1, 2.
- Premium grade hot and cold rolled steel.
- Designed and manufactured under ISO 9001:2008 and ISO 14001:2004
- Five stage iron-phosphate pretreatment with powder coat finish.
- Tested to 500 hours salt spray under ASTM-D610-01 and ASTM-B117.
- All materials RoHS compliant. 

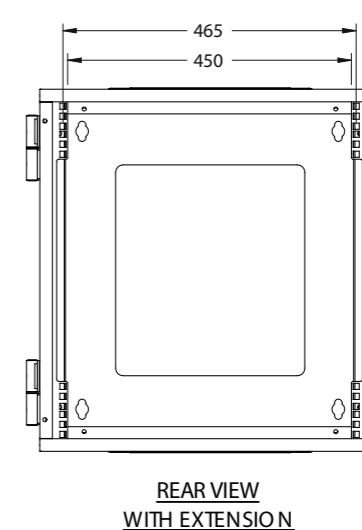
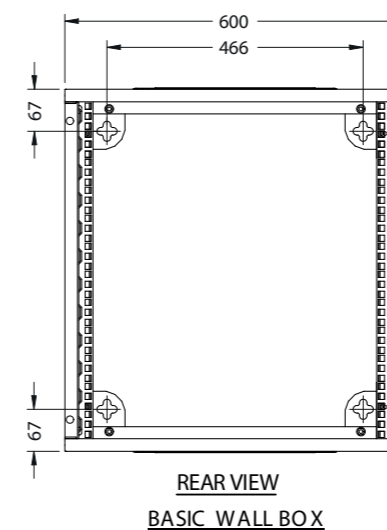
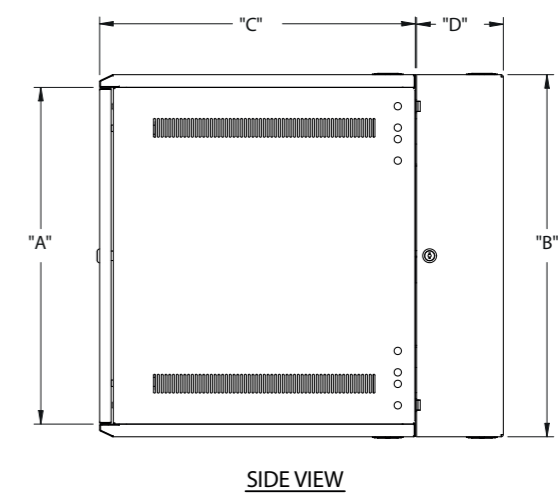
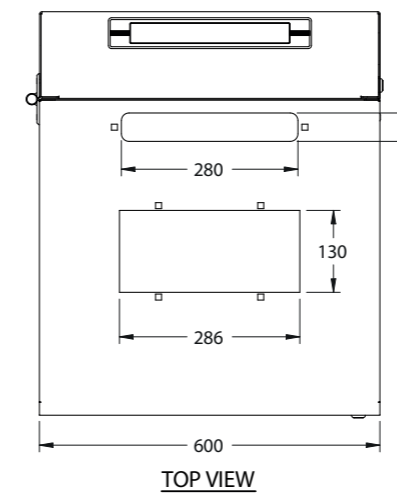

MODEL	"A"	"B"	Extension Kits*	
			"C"	"D"
6U	266	307	350	140
9U	400	441	500	140
12U	534	575	500	140
18U	801	842	500	140

Dimension in mm.





Basic Unit



Basic with Top/Bottom cover 6U



Basic with Top/Bottom cover 4U

Wall Mount Open Frame

The ideal solution for cable and patch panel installations, our wall mount open frame series is both a space and budget saver. The open architecture and hinged front mounting angle allow for maximum access

Features

- Simple and fast installation
- Hinged front 19" rail for convenient equipment integration
- Load tested to 18 kg
- Ample cable access openings at rear and side
- Large cut out at rear panel fits over wall power points
- Numerous cable tie off points provided
- Optional cover and base panel are available

Our Standard Configurations

- Heights: 2, 4 and 6U
- Depths: 100, 200 and 300 mm
- Color: Low gloss textured black
- Packing can be bulk packed or kitted

Industry Standards and Materials

- Dimensions conform to EIA-310E and IEC-60297-1, 2.
- Premium grade cold rolled steel.
- Designed and manufactured under ISO 9001:2008 and ISO 14001:2004
- Five stage iron-phosphate pretreatment with powder coat finish. Tested to 500 hours salt spray under ASTM-D610-01 and ASTM-B117.
- All materials RoHS compliant.



Our SA Series

of stand alone general use electronic enclosures is a highly versatile line of quality enclosures for both industrial and hobbyist use. The rugged steel body provides easy access to the components being assembled inside. The Aluminum front and rear panels are ideal for end user customization.

Available in 24 different sizes and configurations, the SA Series enclosures come flat packed and its unique "snap together" design requires only 4 screws to complete the assembly.

Standards and Materials

- Heights from 1.5U to 5U, conforms to IEC-60297
- Widths of 230mm, 305mm and 432mm
- Depths of 178mm and 279mm
- Premium grade cold rolled steel and aluminum.
- Designed and manufactured under ISO 9001:2008 and ISO 14001:2004
- Five stage iron-phosphate pretreatment with powder coat finish.
- Tested to 500 hours salt spray under ASTM-D610-01 and ASTM-B117.
- All materials RoHS compliant.

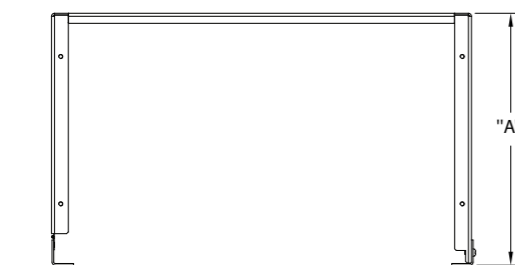
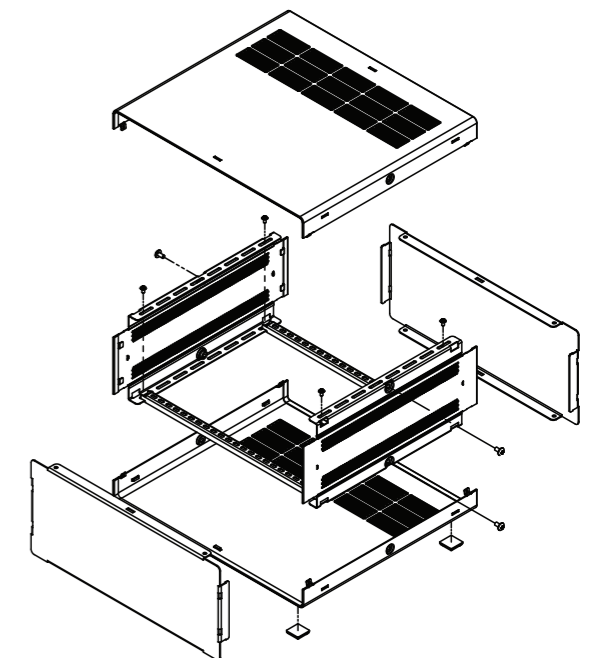

MODEL	"A"	"B"
2U-100D	100	89
4U-100D	100	178
6U-100D	100	267
2U-200D	200	89
4U-200D	200	178
6U-200D	200	267
2U-300D	300	89
4U-300D	300	178
6U-300D	300	267

Dimension in mm.

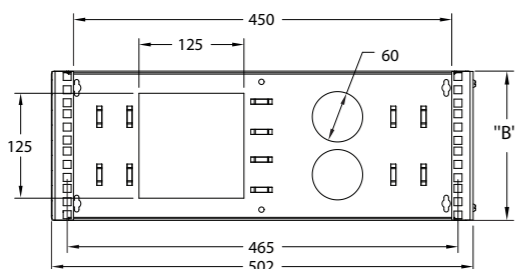

FRONT VIEW

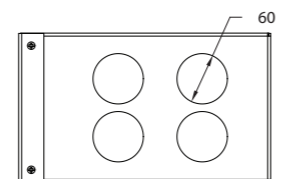

SIDE VIEW

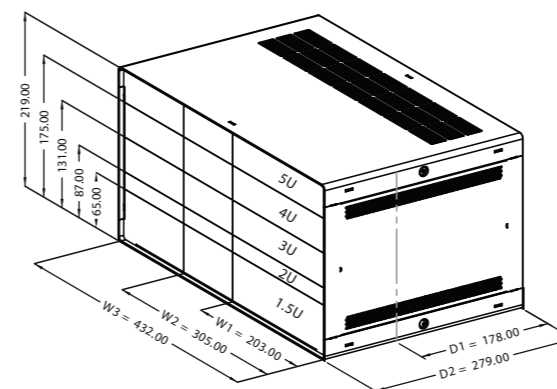

Model Code	Dimension (MM.) H x D x W	Model Code	Dimension (MM.) H x D x W
1.5U-D1-W1	65 X 178 X 203	3U-D1-W2	131 X 178 X 305
1.5U-D1-W2	65 X 178 X 305	3U-D1-W3	131 X 178 X 432
1.5U-D1-W3	65 X 178 X 432	3U-D2-W1	131 X 279 X 203
1.5U-D2-W1	65 X 279 X 203	3U-D2-W2	131 X 279 X 305
1.5U-D2-W2	65 X 279 X 305	3U-D2-W3	131 X 279 X 432
1.5U-D2-W3	65 X 279 X 432	4U-D1-W2	175 X 178 X 305
2U-D1-W1	87 X 178 X 203	4U-D1-W3	175 X 178 X 432
2U-D1-W2	87 X 178 X 305	4U-D2-W1	175 X 279 X 203
2U-D1-W3	87 X 178 X 432	4U-D2-W2	175 X 279 X 305
2U-D2-W2	87 X 279 X 305	4U-D2-W3	175 X 279 X 432
2U-D2-W3	87 X 279 X 432	5U-D2-W1	219 X 279 X 203
		5U-D2-W2	219 X 279 X 305
		5U-D2-W3	219 X 279 X 432





The PF-19 Series of rack mounted 19" Enclosures, is very versatile and user friendly. Designed for both professional users and home hobbyists alike, our latest version continues the trend of reducing hardware and maximizing user convenience. The heavy duty electro-galvanized steel body features perforated, removable top and bottom panels providing ample ventilation and easy access to work inside. The 3.00 mm thick Aluminum front and rear panels are easily worked to your specification.

Our customized extruded aluminum mounting rails are slotted to allow for convenient PCB and component installation. PF-19 is provided with self adhesive rubber feet if rack mounting is not required.

Standards and Materials

- Heights from 1U to 5U
- Depths of 245mm, 335mm and 425mm
- Dimensions conform to IEC-60297-3.
- Premium grade electro-galvanized steel and aluminum.
- Designed and manufactured under ISO 9001:2008 and ISO 14001:2004
- Five stage iron-phosphate pretreatment with powder coat finish.
- Tested to 500 hours salt spray under ASTM-D610-01 and ASTM-B117.
- All materials RoHS compliant. 

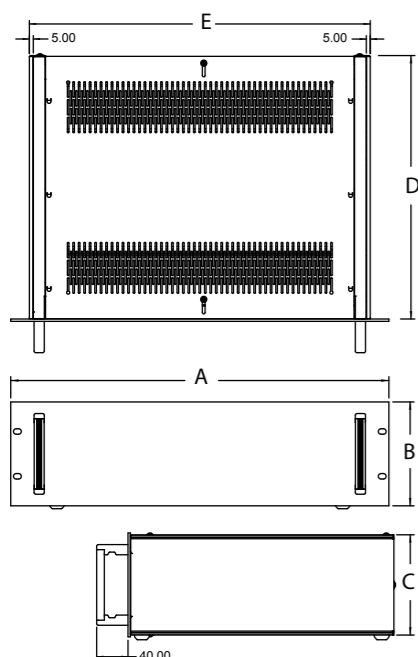

Item #	Model	Front Panel Size (MM.) (A x B)	Cabinet Size (MM.) (E x D x C)
1	1UD0	482.60 x 43.70 x 3.00	425.00 x 90.00 x 38.70
2	1UD1	482.60 x 43.70 x 3.00	425.00 x 245.00 x 38.70
3	2UD1	482.60 x 88.10 x 3.00	425.00 x 245.00 x 83.10
4	2UD2	482.60 x 88.10 x 3.00	425.00 x 335.00 x 83.10
5	3UD2	482.60 x 132.60 x 3.00	425.00 x 335.00 x 127.60
6	3UD3	482.60 x 132.60 x 3.00	425.00 x 425.00 x 127.60
7	4UD2	482.60 x 177.00 x 3.00	425.00 x 335.00 x 172.00
8	4UD3	482.60 x 177.00 x 3.00	425.00 x 425.00 x 172.00
9	5UD2	482.60 x 221.50 x 3.00	425.00 x 335.00 x 216.50
10	5UD3	482.60 x 221.50 x 3.00	425.00 x 425.00 x 216.50
11	6UD3	482.60 x 265.90 x 3.00	425.00 x 425.00 x 261.00
12	6UD4	482.60 x 265.90 x 3.00	425.00 x 465.00 x 261.00

Power Distribution Units :

Power management is one of the most important aspects of your infrastructure setup. Our range of PDU's starts with basic stand alone devices to intelligent types capable of monitoring power and environmental factors.



ACU Series : Universal Socket Type

- 12 or 24 Sockets per strip (6 for 19" version)
- Zero U or 19" mounting options.
- Available in 220 VAC 16A, and 32A
- LED indicator to monitor the power status
- 16A or 32A circuit breaker, with finger guard to prevent accidental switching.
- High quality 16A, and 32A AC power plugs (IEC 309)
- Maximum 10 ampere current rating on each outlet
- Single Phase

ACPI Series : Monitored PDU : IEC 60320F Socket Type C-13

- Hot Swap multi function LCD display shows real time Voltage, Current and Frequency
- Zero U mounted
- Readout can flip 180 degrees for easy viewing
- 24 x C-13 sockets in four banks of 6 sockets
- 32A hydraulic magnetic circuit breaker with finger guard to prevent accidental switching.
- Max 10 amp per socket and max 15 amp per each bank of 6 sockets.
- Single Phase



Multi function LCD display features:

- Real time volt and amp meter
- Display AC voltage : 100-240 volts
- Display AC current : 0-100 Amperes (RMS)
- Display line frequency : 47-63Hz.

Note: This model is available without display module.

Arion PDU Server and Environmental Monitoring

The Arion PDU Server enables the intelligent features embedded in the Arion Monitored PDU. One IP address can support 8 PDU's and environmental monitors.



- Plug and play enabled Ethernet access for system setup and remote monitoring.
- Email, SMS and SNMP trap provides instant warning in case of abnormal event.
- 1U rack mounted uses only 1 U of rack space.
- Four output control ports to manage relevant devices
- One dry contact input for access control
- One sensor input port to monitor temperature and humidity – can expand up to 7 sensors with optional environmental sensor kit.
- One RDIF input port.
- Firmware upgrade on line

Sensor Expansion Module (SEM)

The Arion PDU server comes with one port for a combo temperature / humidity probe. Our Sensor Expansion Module (SEM), expands this by adding 6 more temperature sensors.

- Plug and play enabled
- SEM has one on board temperature/humidity sensor
- Additional 6 ports available for total of 7 sensor probes
- Pre-installed software allows for remote monitoring.
- LCD readout with selector button allows for local monitoring
- Probes come with 1.8 meters of cable





Your rack installation is not complete without the proper accessories. Our range of products will improve your experience both during installation and after the fact in maintenance and expansion situations. Due to the changing and expanding of our accessories, please do not hesitate to inquire if a product you need is not shown.

Shelves and Support :



19" Adjustable Shelves :

Easily installs into any 19" standard rack, our shelves offer some 250 mm of adjustment inside the rack. Load rated to 90 kg, they come in standard depths of 700 and 800 mm.



19" Sliding Shelves :

For added convenience and accessibility, try our sliding shelves. A high quality bearing slide mechanism provides smooth and convenient action for our shelves. Standard depth is 700 mm, with load rating of 50 kg.



19" Light Equipment Shelves :

These shelves mount directly to the front of the 19" vertical rails and can support loads up to 5 kg. Our selection of seven heights and depths will provide the most suitable solution for you. Ideal for smaller non-rack mountable devices.



Support Rails (Chassis Runners) :

For supporting heavier loads our support rails can handle up to 50 kg load. The rails come in pairs and are 1.50 thick steel with our standard powder coat finish. These rails mount inside the 19" mounting rails.

CABLE MANAGEMENT :



19" Cable Management Panels :

Our 19" mounted cable panels provide the solution to those loose cables in the front of your rack. Our panels are available with either steel cable hoops or steel fingers and come in 1U and 2U heights. Solid or pass through access cut into the panels and numerous slots provided as cable tie off points make these very user friendly.



Vertical Cable Rails and PDU Rails :

These handy rails mount to the side braces inside the rack and provide numerous options to install cable hoops, cable ties as well as zero U installation for power distribution units (PDU). Numerous cutouts allow for cable pass through to adjoining racks or other locations inside the rack.



Side Channel Covers :

A variety of covers for our 800 wide Arion rack provide both cable management and air flow control. These covers easily install into the channel between the cabinet frame post and 19" mounting rails. The blank version serves to prevent hot exhaust air from rear of cabinet re-circulating to the front and mixing with cold air. We offer two versions with cable management capability, including brush strips to seal the area around the cables. Our steel cable hoops can be mounted in many of the holes provided.



Steel Cable Hoops :

Sturdy heavy grade steel hoops which can easily be installed in any of the 9.5mm square holes found in a variety of locations inside the rack, or in the purpose designed installation holes as found on the PDU rails or Side Channel Covers. The hoops provide a flexible and cost effective cable management system. The round contour is easy on your cables and the off set openings allow easy entry for cables.



THERMAL MANAGEMENT :



Base Panel and Plates :

For thermal management or security concerns, close up the open base with Base Filler panels. The panels are provided with smaller openings to allow cable access, with optional adjustable filler plates to wholly or partially close these openings.



Brush Strips :

Cables must frequently be routed through open channels within the racks. To allow cable pass through but prevent unwanted hot air returning to the front of the rack or other hot spots, our brush strip panels provide a good solution. These panels mount to the top panel or side channel covers on our 800 wide racks.



**19" Blank Panels
Tool less and Standard :**

A frequently over looked component in air flow management, blank or filler panels allow you to close up unused U space and properly direct air flow. Available in 1U through 5U, in both tool less and standard formats. Our tool less versions have gaskets to provide an excellent seal against unwanted air leakage.



Fan Trays :

For supplemental air flow management and to counter hot spots, we provide two or three way fan trays. The fan trays mount to the top panel. Fans are AC and available in 110 or 220 volt, various power plugs to match your geographic location.

HARDWARE AND ACCESSORIES :



Document Wallet :

Convenient compartment for storing documents or disks. Approximately 10" square, the document wallet attaches to a door in a location suitable for your needs.



Hardware Bag :

Useful set of 50 pieces of M6 caged nuts, plastic cup washers with matching screw with a handy caged nut installation/removal tool.



Casters :

All of our casters are high quality and rigorously tested. Standard casters rated at 285 kg and Heavy Duty Casters rated at 400 kg. Rated to UL-94 HB.



Baying (Ganging) Kits :

Easy to install, these baying kits allow you to securely attach multiple racks together in rows. Can be used on either 19" or 23" centers.



Bolt Down Brackets :

Secure your rack in position with our bolt down brackets. Attach to the front and rear of the frame then into the floor. These sturdy brackets also serve to bolt the assembled rack to a shipping pallet.

