

ARION SOLIS 800W SERIES 19" Network Cabinet



Product Information

Arion Solis 800 series is designed for both large and small networking deployments. Primarily for networking and structured cable installations, Solis is also ideally suited for mixed IT environments using networking, server, storage and other IT gear.

Features

- Extra width for convenient internal cable routing and thermal management
- Cable access through top or base
- 800 KG load capacity
- Contoured high density perforated door exceeds 80% open area
- Vendor neutral, accepts any 19" standard rack mounted product
- Light weight and strong.
- Split level side panels provide convenient access to installed equipment.
- Depth adjustable 19" vertical mounting rails in 20 mm increments
- "U" numbers printed on 19" rails.
- Knock down design for efficient shipping.
- Up to 120 sets per 40' container (bulk pack)
- Quick assembly time, approximately 20 minutes.
- Lift off door type for quick release
- Field reversible doors.
- Flexible packing methods allows for convenient stocking and end user delivery.



Standards and Materials Summary

- Dimensions conform to EIA-310E, IEC-60297-1, 2
- Five stage iron-phosphate pretreatment with textured powder coat finish, tested to 500 hours salt spray under ASTM-D610-01 and ASTM-B117
- Standard color is low gloss textured black
- Premium grade Hot and Cold rolled steel sheet
- Designed and Manufactured under ISO 9001:2015 and ISO 14001:2015
- All materials RoHS compliant 

Technical Specifications Summary

Cabinet Model	1000 Deep		1100 Deep		1200 Deep	
	42U	45U	42U	45U	42U	45U
Overall Height of Rack including Casters	2020	2153	2020	2153	2020	2153
Overall Depth, Door to Door (See page 3)	1065	1065	1165	1165	1265	1265
Rack Depth, Frame to Frame (See page 3)	1000	1000	1100	1100	1200	1200
Usable Rack Height	42U	45U	42U	45U	42U	45U
Net weight (Kg.) (Include Casters)*	109	114	113	118	118	123
Maximum Mounting Depth (mm)	929	929	1029	1029	1129	1129
Single Door Total Open Area (sq in), all exceed 80%	1466	1571	1466	1571	1466	1571
Double Door Total Open Area (sq in), all exceed 80%	1397	1488	1397	1488	1397	1488
Door opening radius	132°	132°	132°	132°	132°	132°

* Weights will vary based on options and accessories.



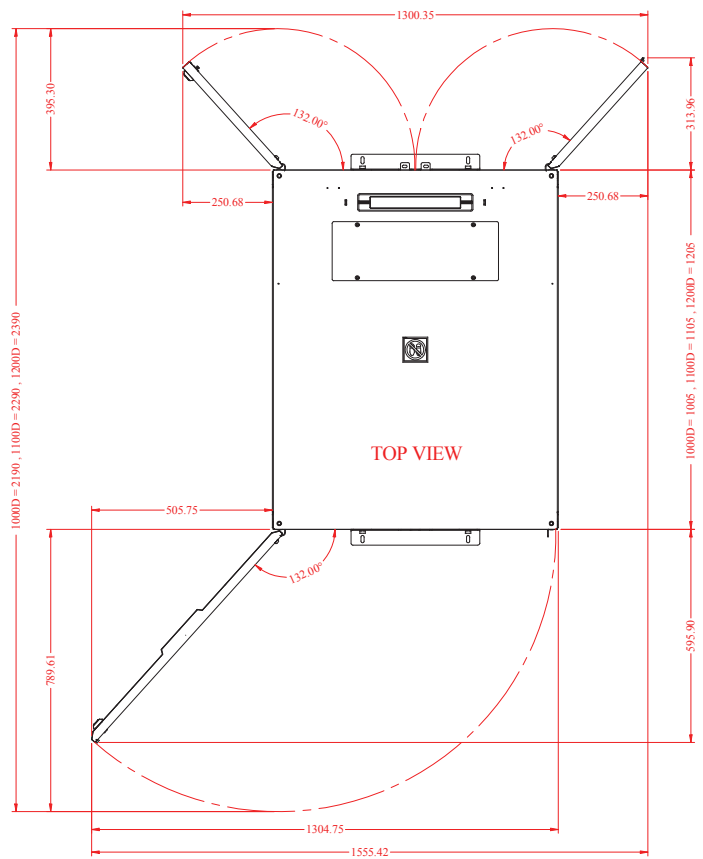
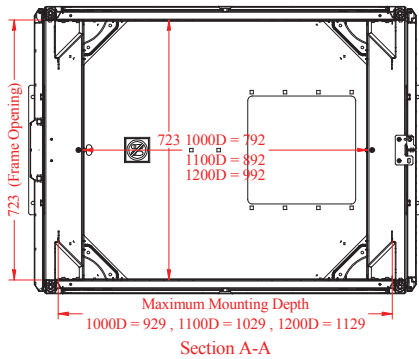
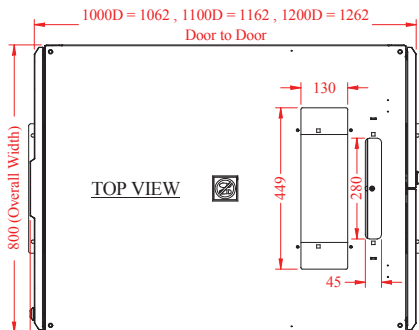
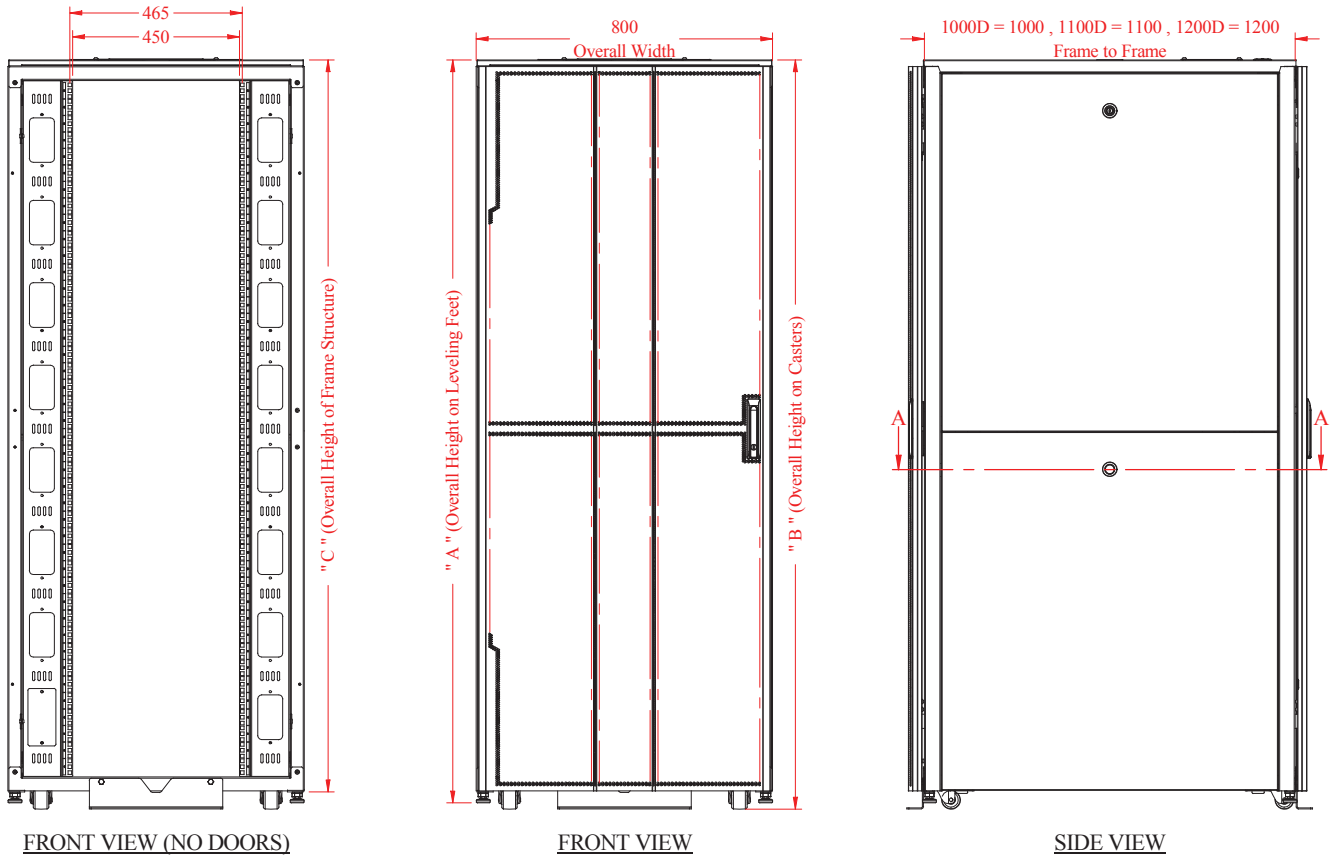

DIMENSIONS (UNIT : MM)			
UNIT HEIGHT	DIM. "A"	DIM. "B"	DIM. "C"
42U	2003	2020	1973
45U	2136	2153	2106

