



Standard wallbox



Wallbox with extension kit



Our Wall Net series of 19" wall mounted enclosures offer a sturdy and secure enclosure in a compact package. Ideal for remote installations of routers, switches, UPS and patch panels.

Features

- Vendor neutral will accept any standard 19" mounted device.
- Integrated 19" mounting rails incorporated into adjustable inner frame for extra strength.
- Two cable entry slots on the top and bottom of the enclosure.
- Knock down design.
- Simple installation using template for locating mounting points on wall.
- Reversible door allows flexibility at installation site.
- Supports loads up to 140 kg. for standard wall box.
- Supports loads up to 40 kg. with extension kit.

Extension Kits: (Optional component)

Expand the functionality of the WallNet with our extension kits. These kits, available in 140 mm depths provide both extra depth plus convenient access to the rear of the cabinet. The extension frame is first installed in the preferred location. The basic wall box is then installed using the lift off hinges, either left or right hand oriented. This convenient lift off hinge allows a single person to handle the installation.

Our Standard Configurations

- Color: Low gloss textured black
- Depth: 500 mm deep
- Depth Extension Kits: 140 mm.
- Width: 600 mm external
- Height: 6, 9, 12 and 18U. Additional sizes available upon request.
- Packing: Bulk packed, flat pack kitted or assembled

Industry Standards and Materials

- Dimensions conform to EIA-310E and IEC-60297-1, 2.
- Premium grade hot and cold rolled steel.
- Designed and manufactured under ISO 9001:2008 and ISO 14001:2004
- Five stage iron-phosphate pretreatment with powder coat finish. Tested to 500 hours salt spray under ASTM-D610-01 and ASTM-B117.
- All materials RoHS compliant. 

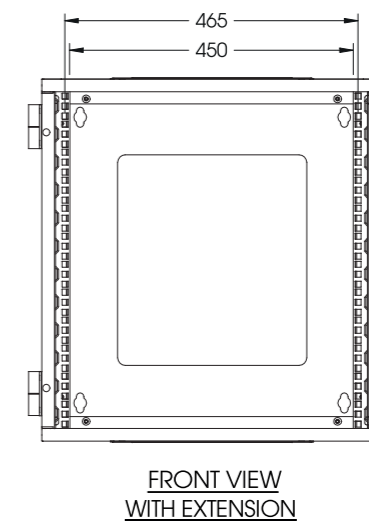
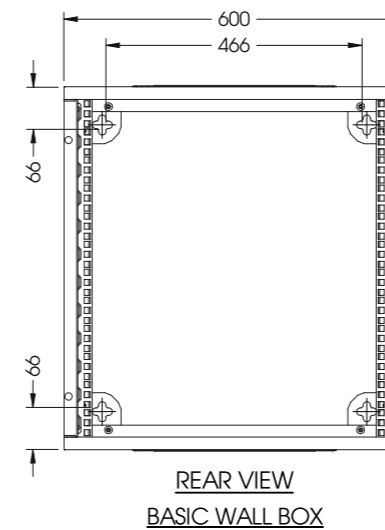
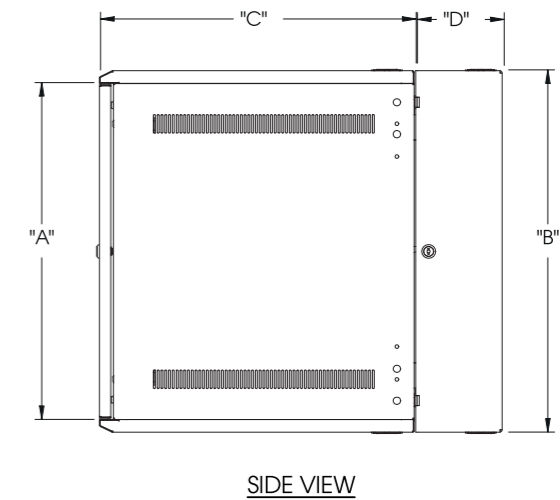
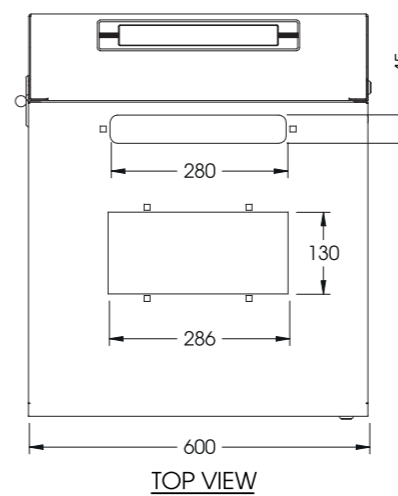

MODEL	Extension Kits*			
	"A"	"B"	"C"	"D"
6U	266	307	500	140
9U	400	441	500	140
12U	534	575	500	140
18U	801	842	500	140

Dimension in mm.

